

CAA-500 MarkII

C★MET ANTENNA

Standing wave Analyzer
1.8 - 500MHz

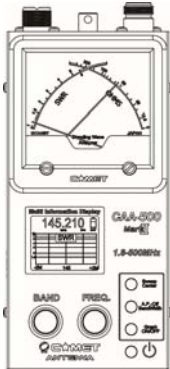

Instruction Manual

Thank you for your purchase of this instrument. It was built under tight quality control standards and procedures; however, there is always the possibility of damage during shipping. Should this occur, please notify the dealer from whom you purchased it immediately so they can initiate the damage claim process with the shipping company. Please read this manual completely before beginning operation, so as to understand its features and capabilities fully.

◆ Features

- Built-in broadband high-stability transmitter for easy measurement of resonant frequency, SWR, and impedance.
- Color LCD & cross-needle meter display provide SWR and Impedance information simultaneously.
- Separate ham band segments can be swept to display the SWR characteristics in the graph automatically. Moreover, it is possible to plot the SWR characteristics manually with user-defined center frequency and sweep bandwidth.
- Size AA alkaline (manganese) or Ni-MH rechargeable batteries (six required) may be used. Typical battery life is 9 hours of continuous operation when using AA cells.
- External 8-16V DC power may be used to power the meter; this allows trickle charging of Ni-MH cells.
- The programmable Auto Power Off function preserves battery capacity in case you forget to turn the meter off.
- A hand strap post is provided, for ease of use and to minimize the chance of dropping the CA-500 MarkII.



Important Cautions

- ◆ This is a delicate measuring instrument; please take care not to drop it or subject it to physical shock.
- ◆ The impedance bridge of this instrument is immediately inside the antenna connection point. ***Be absolutely certain not to apply power from an external transmitter, as this will damage the CAA-500 MarkII.***
- ◆ Strong local RF fields (in a multi-station environment, for example) may cause unstable SWR readings.
- ◆ When not using Ni-MH batteries, always turn OFF the Charge switch on the battery case. Failure to do so may result in battery rupture, leakage and/or explosion if you apply charging voltage to alkaline cells.
- ◆ The external DC supply voltage must be between 8V to 16V, and the current supplied must be at least 250mA. Never apply DC voltages greater than 16V, nor AC voltage of any kind. Our warranty does not cover damage caused by the use of an improper power source.
- ◆ When using AA batteries, the LCD display will become unstable when the batteries are weak. Change Batteries as soon as the display starts blinking, and change all batteries to improve the battery shelf life.
Remove the batteries when not in use for extended periods of time to avoid damage caused by leakage.

▼ Before using



- ◆ **To avoid ESD damage, it is important to discharge any static electricity that may have accumulated on the antenna system by touching grounding the antenna's coax cable connector before screwing it onto the SWR analyzer.**

◆ Panel/Case Parts and Descriptions

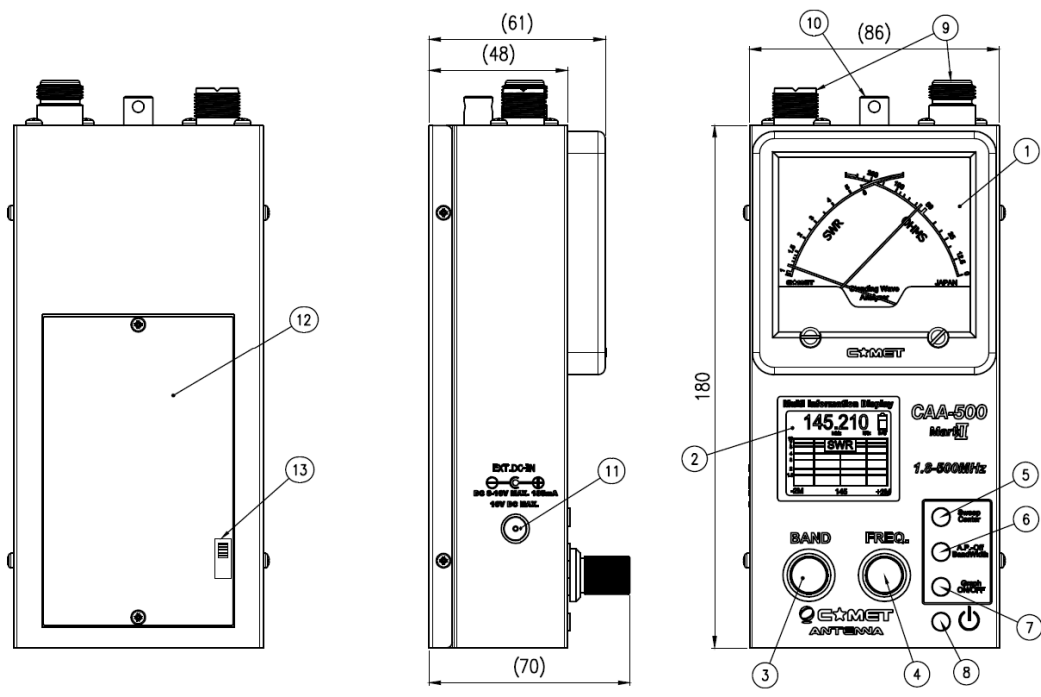

- ① **Display Meter** This Cross Meter displays both SWR and Impedance simultaneously.
- ② **Multi-function Display** The color LCD (Liquid Crystal Display) shows frequency, amateur band, and SWR data (impedance (Z)/resistance (R)/reactance (X)), and also can provide a swept-frequency SWR graph.
- ③ **BAND Knob** This knob is used to select the frequency band within the range 1.8 to 500 MHz. Clockwise rotation of this knob selects a higher frequency band. It is also used for setting of the APO (Automatic Power Off) function.
- ④ **FREQ.Knob** This knob is used to set the frequency within the selected amateur band. Clockwise rotation increases the frequency, while counter-clockwise rotation lowers the frequency.
- ⑤ **SWEEP/CENTER Button** In the “Normal” mode, pressing this button starts an SWR sweep of the band.
 - When in the SWR Graph mode, pressing this button sets the current display frequency to be the center frequency of the graph. In this mode, rotate the (3)BAND knob to adjust the Sweep width; press the (6) A.P.OFF/WIDTH button to confirm. Now rotate the (4) FREQ knob to create and display the SWR plot.
- ⑥ **A.P.-OFF/BANDWIDTH Button** In the “Normal” mode, press and hold in this button for three seconds to allow setting of the Auto Power Off feature’s time interval.
 - In the “Manual” plot mode, pressing this button allows you to set the bandwidth of the SWR Sweep.
 - While in the “Manual” plot mode, pressing this button allows you to change the color of the SWR Graph.
- ⑦ **GRAPH ON/OFF Button** Press this button to switch between the “Normal” mode and the SWR Graph modes.
- ⑧ **POWERButton** This is the main Power On/Off button for this device. Press once to turn the unit on, and again to turn it off.
- ⑨ **RF Connectors** These are the coaxial jacks used for connection to the coaxial cable. The left connector is an “M” (“UHF”) type (used for 1.8-300 MHz), while the right jack is Type N, used for 300-500 MHz. Switching is automatic, based on the Band setting.
- ⑩ **Hand Strap Mounting Bracket** You may connect a commercially-available hand strap here. As the diameter of the mounting hole is greater than 1 mm, a sturdy strap (highly recommended) may be attached.
- ⑪ **External DC Power Terminal** External DC (8-16V) may be connected here. The center pin is positive (+).
- ⑫ **Battery Case** This is the housing for six AA cells. Please install them according to the inscription inside the case.
- ⑬ **Charge Switch** (Inside Battery Case) This is the switch for enabling/disabling trickle charging of Ni-MH cells, if used.

When using Alkaline or similar batteries, be sure to set this switch to the OFF position. In the event of battery leakage, serious damage to this unit may occur if the switch is set to ON during use.

(※) Trickle charging is useful to help maintain a full charge on your battery by compensating for the slight self-discharge that can occur even without a load being placed on the batteries

Before You Start

This instrument has been calibrated with the unit being held *horizontally*, with the meter facing up. The discussion below is an operating example; the parameters you set may affect the actual results.

Incidentally. . .

Because of stray inductance and capacitance, it is possible for the meter to show a “quasi” resonant frequency. If the measured “resonant” frequency is different from what you expected, inspect your system for these possible issues, in addition to those mentioned previously.

◆ Using the Graph Mode to Display SWR vs. Frequency

There are two types of Graph mode on this meter. You may use a predetermined center frequency and bandwidth to perform an SWR sweep, and alternately you may set an arbitrary center frequency and bandwidth to perform a manual SWR sweep.

Auto Sweep Mode (“SWR” caption around center of Graph shown in Red)

1. While in the Normal display mode, press the SWEEP/CENTER button to initiate an automatic sweep. The center frequency and sweep bandwidth will be based on the Band that is currently selected.
2. While the Sweep is in progress, the “SWR” caption will blink. A band Sweep typically takes about 25 seconds to complete.
3. Once the Sweep is completed, you may repeat the Sweep as many times as desired by just pressing the SWEEP/CENTER button again.
4. To return to the Normal Mode, press the GRAPH ON/OFF button. Note that the FREQ and BAND knobs are disabled in the Sweep Mode.



Auto Sweep Mode

Manual Plot Mode (“SWR” caption around center of Graph shown in Green)

1. While in the Normal display mode, press the GRAPH ON/OFF button to enter the Manual Plot mode. A green “SWR” box will appear.
2. The SWR Graph will now be displayed; use the BAND and FREQ knobs to set the desired center frequency for the manual SWR Sweep.
3. Press the SWEEP/CENTER button.

The center frequency (rounded to three digits) will appear in the center of the Graph, and the Sweep Limits (left and right at bottom) will blink.

4. Use the BAND and/or FREQ knobs to set the Sweep bandwidth, then press the A.P.OFF button to confirm the setting.
 - Because the BAND knob causes huge frequency shift, generally you will use the FREQ knob to set Sweep Limits.
5. After the setup is finalized, rotate the FREQ knob to perform the Manual Sweep. Gradual rotation of the FREQ knob allows precision measuring to be performed (minimum resolution 1 kHz).
6. If you press the AP-OFF button during a Manual Sweep, the color of the plot will change (Red -> Blue -> Green -> Purple -> Orange -> Red. . .).
7. If you want to change the bandwidth in this mode, press the SWEEP/CENTER button again.
8. To return to the Normal mode, press the GRAPH ON/OFF button.

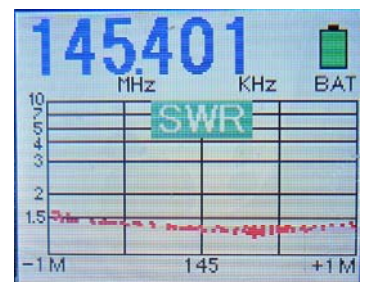

Manual Plot Mode

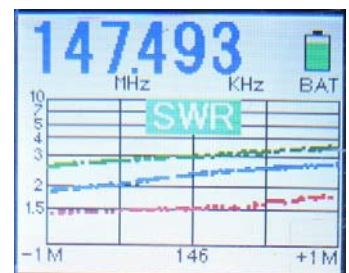

Note: You can not preserve the Graph data if you change Graph Modes

● Setting the Auto Power Off Time

■ This procedure sets the Auto Power Off timer, to preserve battery life after meter inactivity.

In the Normal mode, press and hold in the A.P.OFF button for more than three seconds; the currently-set Auto Power Off time will be shown on the display (factory default: 5 min.). Rotate the BAND knob to change the timer in one-minute increments (0 – 9 min.). When done, press the A.P.OFF button momentarily.

● If the timer is set to 0 minutes, the Auto Power Off function will be disabled.

● When power is turned off, this setting will be saved.

Rotate the BAND knob to change the APO time.

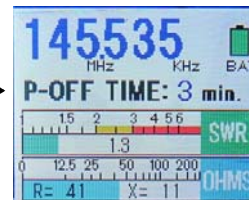

• Note that the meter will consider frequency change of less than 3% to be “inactivity” when counting down the Auto Power Off timer.

Quick-Reference Operation Chart

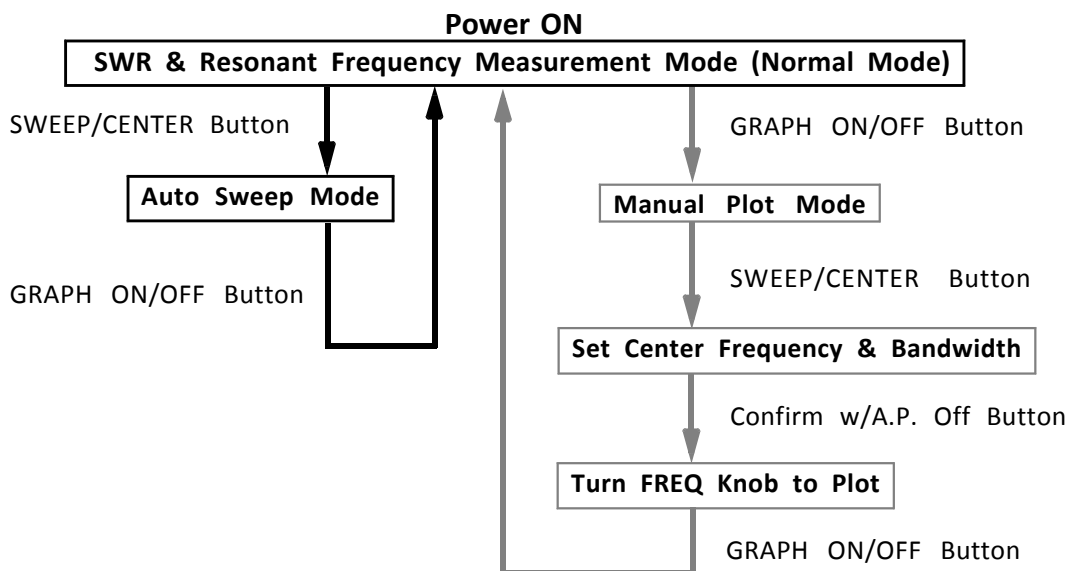

● Regarding the Charging and Use of Nickel-Metal Hydride (Ni-MH) Batteries

• This meter can be used either with alkaline or Ni-MH rechargeable batteries.

• If using Ni-MH batteries, they may be trickle charged inside the case.

• To trickle charge Ni-MH batteries, you must set the small slide switch inside the case (near the battery holder) to the CHARGE ON position. A small flat screwdriver is ideal for this purpose.

■ When the battery level indicator changes from yellow to red, apply 12-14V DC to the DC IN jack to trickle charge the Ni-MH batteries. A full charge takes about 14-15 hours. Wait until the battery indicator shows yellow or red before charging, to avoid “charge memory” effect.

■ Charging of Ni-MH cells can be done with as little as 11V DC, but it may take several dozen hours to achieve a full charge. If the DC voltage is above 14V, the batteries may charge, but their lifetime will be shortened.

• Trickle charging will occur, regardless of the setting of the meter’s main Power On/Off Switch, if 12-14V DC is present at the DC IN jack.

• The trickle charge current is very low, but we recommend that you turn off and disconnect the DC power source used for charging if you will be away from the unit for a long time.



Be certain to turn the charging slide switch to OFF when using alkaline cells!
If you neglect to turn this switch off, and attempt to charge alkaline cells, battery leakage may occur, which can cause serious damage to this unit (not covered by our Limited Warranty).
Also, do not use a combination of alkaline and Ni-MH batteries, as damage can occur in case of an unexpected accident.

● About Error Messages

If an error occurs during Sweep operation, an error message will appear at the top right. In this case, ER1 indicates that the frequency of interest could not be set.

Frequently, very strong local RF fields can cause erratic meter operation and/or incorrect SWR readings. Try to eliminate the strong RF fields and try again.

If ER1 appears even with no antenna connected, there may be an internal malfunction in the meter. Contact your dealer for repair assistance.

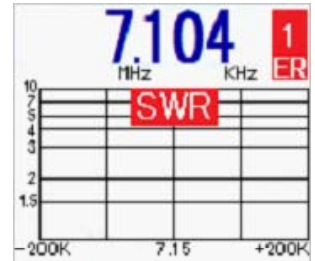

If ER2 appears immediately after powering up the unit, it means that the internal flash data is corrupted.

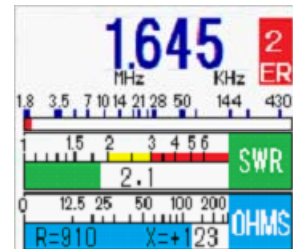

Flash Data Recovery Procedures

1. Press and hold in the GRAPH ON/OFF key; while holding it in, press the POWER key to turn on the CA-500 MarkII.

- Release the GRAPH ON/OFF key when prompted.
- The version number for the unit's firmware will; now appear on the LCD.

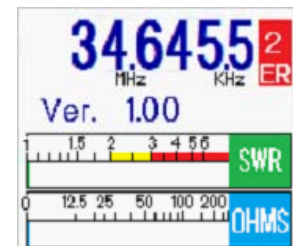

2. Now press the GRAPH ON/OFF key.
 [BAND A] will be displayed.

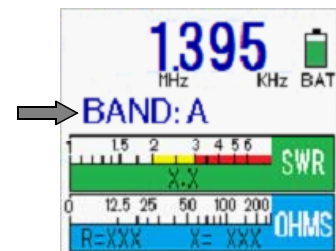

3. Press the GRAPH ON/OFF key again. [AUTO: 1] will be displayed.

- Set the FREQ knob to the center of its range.
- Do not move the FREQ knob hereafter during this procedure.

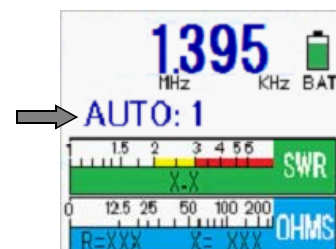

4. Press the CENTER key. An automatic adjustment process will begin; you will notice a number incrementing upward.

5. After about two minutes, [COMP: 35] will be displayed. The procedure is now complete.

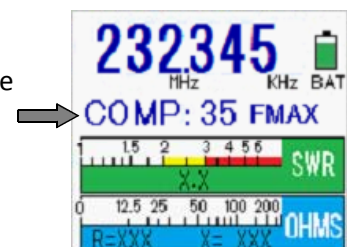

6. Now turn the CA-500 MarkII off.

Q. When the antenna connected, the resonant frequency appears shifted or there is no SWR dip.

Ans. On an antenna not requiring radials, the case of this unit is the “ground” and it is possible, due to common mode current flow or other reasons that the meter may be situated in a position that causes radically unusual readings to occur. Try to relocate the meter as close to the antenna as possible to see if this eliminates the problem (holding the meter in your hand is often sufficient to suppress common-mode current).

Q. Even with a known 50-Ohm impedance, the SWR does not indicate a low value.

Ans. The impedance that you are viewing is an absolute value that also contains a reactance. It is possible to have the meter show 50 Ohms of impedance without a 1:1 SWR.

Try to get the reactance as close to zero as possible; in this instance, with a total impedance of 50 Ohms and nearly zero reactance, the SWR will be 1:1 (ideal situation).

In this MkII version, a reactance display has been added. Because it shows the absolute value of reactance (no “+” or“- ”), you cannot initially tell if the reactance is capacitive or inductive. Generally, if the impedance is capacitive (-), then making the antenna shorter (in the case of a dipole or Yagi driven element) will cause the reactance to increase. If the impedance is inductive (+), making the antenna longer will cause the reactance to increase.

Q. At what point do I want to use a cable for attachment to the antenna?

Ans. To get the most accurate reading of the impedance, the meter should be either immediately at the feedpoint for the antenna (often impossible) or connected via an integer multiple of a half wavelength of cable at the frequency being measured. However, feedline loss may affect the results even in this case, so you will not see the antenna performance alone, but rather the antenna + cable system performance.

When computing a half-wavelength cable, the velocity factor of the cable must be included. For example, the velocity factor of RG-213 type coax is typically 67%. So for 14 MHz this is 492×12 (for inches) = 5904 divided by 14 (MHz) $\times 0.67 = 421.71$ inches (including velocity factor).

Depending on the cable diameter and attendant losses, the use of cable lengths in excess of 30m (about 100’) may yield inaccurate readings, due to the very low power of this unit.

Q. Is it possible to connect to the “M” (“UHF) and “N” (Type N) jacks simultaneously?

Ans. Because the jacks are automatically switched, according to the frequency in use, there is no way that both jacks may be used simultaneously (the opposite connector cannot be used in case of an incompatibility).

**Notes on Handling**

- **This unit is fragile: do not drop or subject it to a strong shock.**

Physical damage and/or malfunction may occur if unit is dropped.

- **Do not use in very dusty or damp places, or outside in the rain.**

This unit is not waterproof nor dustproof, so damage can occur if it is exposed to spray, rain or severe dust.

- **Please do not disassemble or modify this unit.**

To do so may present danger due to electrical shock; product failure or failure to meet specifications may occur if modified.

- **Please use only at a temperature between 0° and +40° C (+32° to +104° F).**

The Liquid Crystal Display (LCD) may malfunction at low temperatures.

◆ Product Specifications

| | |
|---------------------|--|
| Frequency Range | 1.8 – 500 MHz in 35 range segments |
| Display Type | 1.8 inch TFT Color LCD |
| RF Output Level | 0 dBm (1mW) :HF/VHF , -1dBm(0.8mW): UHF |
| Measured SWR Range | Analog Meter: 1.0 – 6.0; LCD:1.0 – 9.9 |
| Impedance Range | 12.5 – 300 Ohms (Analog and LCD) |
| Resistance Range | 10 – 500 Ohms |
| Reactance Range | 0 – 500 Ohms (Absolute Value) 1.8-190 MHz |
| RF Connectors | “M” (“UHF/SO-239”) for HF/VHF, “N-female” for UHF |
| Operating Temp. | 0° - 40° C (32° - 104° F) |
| Power Sources | 6 x Alkaline or NiMH Rechargeable Cells External Power: +8 to +16V DC |
| Current Consumption | 190 mA or less |
| Charging Time | 15 hours at 12 – 14V DC (trickle charge) |
| Dimensions | 3.5(W) x 7.75(H) x 2.65(D)inch (overall) |
| Weight | 2lbs 2 oz (w/alkaline batteries) |
| Supplied Accessory | External DC Cable (Center pin +/white wire +) |

For After-sale Service

- For questions about this product, contact your dealer or our Technical Support staff
- ◆ For repairs or in case of shipping damage, consult the dealer from whom this unit was purchased.
- This unit has a Limited Warranty for a period of one year from the date of purchase by the original purchaser. Units determined to have manufacturer defects will be repaired or replaced at the discretion of NCG Company.

For warranty inspection, send the unit prepaid to:

NCG Company
Att: Warranty Claims
15036 Sierra Bonita Ln.
Chino, CA 91710-8901
909-393-6133
www.natcommgroup.com
sales@natcommgroup.com

Specifications for this product are subject to change without notice or obligation,
in the interest of ongoing product improvement.

COMET CO., LTD.

Tsuji 4-18-2, Minami-ku, Saitama-City, Saitama 336-0026 JAPAN
TEL: +81 048-839-3131 , FAX: +81 048-839-3136

URL (Japanese site) : <http://www.comet-ant.co.jp>