

MFJ

IntelliTuner™ Remote Automatic Antenna Tuner

Model MFJ-994BRT

INSTRUCTION MANUAL

CAUTION: Read All Instructions Before Operating Equipment

MFJ ENTERPRISES, INC.

300 Industrial Park Road
Starkville, MS 39759 USA
Tel: 662-323-5869 Fax: 662-323-6551

VERSION 1A

COPYRIGHT © 2010 MFJ ENTERPRISES, INC.

Contents

THE BASICS

Introduction	1
Features	2
Specifications	2
Fast Start	3
Internal components.....	4
C-UP and C-DN Buttons	4
L-UP and L-DN Buttons	4
AUTO Button.....	4
TUNE Button	4
POWER Button	4
Connections	5
Transmitter	5
Ground	5
Wire.....	5
Antenna	5
Installation	6

MISCELLANEOUS

Antenna Memory.....	7
Intellitune Algorithm	7
LC Limits	7
Tuner Status Indicators	8
Foldback Circuit	8
Grounding Hints	9
Antenna System Hints.....	9
Location.....	9
Matching Problems	9

APPENDICES

Firmware Version Number	11
Resetting the Tuner.....	11
Factory Defaults	11
Delete Antenna Memory	11
Total Reset.....	12
Self Test	12
Power Down Circuit Test.....	13
Relay Test	13
Frequency Counter Calibration	14
SWR Bridge Calibration	15
In Case of Difficulty	15
Technical Assistance	16
List of Accessories	16
Block Diagram.....	17

The Basics

Introduction

The MFJ-994B *IntelliTuner*[™] lets you rapidly tune unbalanced, single-wire, or balanced (with external balun) antennas automatically.

MFJ's exclusive *InstantRecall*[™], *IntelliTune*[™] and *AdaptiveSearch*[™] algorithms give you fast automatic tuning with more than 10,000 non-volatile *VirtualAntenna*[™] memories. There are four banks of memory, and each memory bank has over 2500 non-volatile memories for tuner settings.

The MFJ-994B *IntelliTuner*[™] includes a highly efficient switching L-network with wide matching capability, 1.8 to 30 MHz coverage, cross-needle power meters, an accessory remote control port, a radio interface port, and heavy-duty 16 amp/1000 volt relays. It is rated at 600 watts PEP SSB, 600 watts CW, and 500 watts continuous carrier modes. This makes the MFJ-994B perfect for use with modern high power output transceivers and Ameritron AL-811/ALS-600/ALS-500 amplifiers, as well as other popular HF power amplifiers limited to no more than 600 watts output power.

A maximum of 192 values of capacitance and 192 values of inductance are available. With the inductance switched between the input and output side, this provides a total of 73,728 L/C tuning combinations. The nominal tuning ranges are 0 to 2950 pF and 0 to 17 μ H.

The MFJ-994B *IntelliTuner*[™] learns and remembers. When you transmit, it automatically adjusts for minimum SWR and remembers the frequency and tuner settings, safely stored in non-volatile memory. The next time you operate on that frequency (or close to it), the tuner settings are instantly restored and you're ready to operate in milliseconds. There are four banks of memory, which can learn and remember more than 2500 frequencies and tuner settings per bank.

When you key your transmitter, MFJ's *InstantRecall*[™] checks its memory to see if you have operated on that frequency before. If so, tuning is instantaneous and you're ready to operate. If not, MFJ's *IntelliTune*[™] algorithm (based on MFJ's famous SWR Analyzer technology) kicks in. It measures the complex impedance of your antenna. Next, it calculates the components it needs and instantly snaps them in. Finally, it fine-tunes to minimize SWR, and you're ready to operate – typically in a fraction of a second.

If the antenna impedance is not within the tuner's measurement range, MFJ's *AdaptiveSearch*[™] algorithm goes into action. Frequency is measured and relevant component values are determined. Only those values are searched for fast tuning. If it still cannot find a match, the search is performed again using a different search pattern.

The target tuned SWR can be set to 1.5 or 2.0. The minimum power to tune is approximately two watts, with maximum SWR tuning accuracy occurring at tuning power levels of 10-20 watts. Manual tuning is also available for "touching up" the tuning if desired.

The MFJ-994B tuner enters a "sleep" mode when idle and when no transmit signal is present, turning off the microprocessor clock to avoid the generation of spurious signals.

Features

- Automatically matches antennas from 12 to 800 ohms impedance
- Handles 600 watts PEP SSB/600 watts CW/500 watts constant carrier
- Tunes in less than 15 seconds, usually less than 5 seconds
- Over 10,000 non-volatile memories for tuner settings
- Four memory banks with over 2500 memories per bank
- Highly efficient switching L-network matching circuit
- 1.8 to 30 MHz continuous frequency coverage
- Selectable target SWR 1.5 or 2.0 (default is 1.5)
- Selectable SWR threshold 0.5, 1.0 or 1.5 (default is 0.5 above target SWR)
- Lighted cross-needle SWR/wattmeter with high, low and auto range options
- Built-in frequency counter for remembering frequency-specific matching values
- SO-239 coax fed antenna connector
- Connector for random wire or single wire antennas
- Optional remote control
- Optional radio interface cables for compatible radios

Specifications

- Impedance matching range : 12 to 800 ohms
- SWR matching range : Up to 4:1 for < 50 ohms and up to 16:1 for > 50 ohms
- Minimum power for tuning : 2 watts (optimum SWR tuning accuracy occurs at 10-20 watts)
- Maximum power while tuning : 100 watts with foldback, 20 watts without foldback
- RF power limit : 600 watts PEP SSB/600 watts CW/500 watts constant carrier
- Frequency range : 1.8 to 30 MHz continuous coverage
- Frequency counter accuracy : ± 1 kHz across HF bands
- Capacitance range : 0 to 2950 pF (192 values)
- Inductance range : 0 to 17 μ H (192 values)
- Relay rating : 16 amp 1000 volts
- Relay electrical life : 100,000 operations
- Relay mechanical life : 10 million operations
- Memory endurance : 1 million write cycles
- Memory data retention : > 200 years
- Power requirements : 12 - 15 volts DC
- Current consumption : 850 mA or less
- Dimensions (connectors not incl.) : 10.1 x 2.8 x 9.2 in; 257 x 71 x 234 mm (w x h x d)
- Weight : Approx. 3.7 lb; 1.68 kg

† Specifications and design are subject to change without notice.

Fast Start

WARNING

- **Never operate the tuner with its cover removed. Contact with the components inside the tuner while transmitting will result in painful RF burns.**
- **Locate the tuner so that the terminals are *not accessible* during operation. The single wire connection may have high voltage while transmitting.**
- **Disconnect all antennas from the tuner during lightning storms.**
- **Always tune with low power (2-10 watts). Apply maximum power only after tuning up.**
- **Never exceed tuner specifications.**
- **Do not transmit with a high SWR for extended periods of time.**

1. Connect the transmitter to the “**RF IN/OUT**” coaxial connector on the **MFJ-4117 Bias-Tee** using a 50-ohm coaxial cable. (See Figure 1) This is the RF signal input connector.
2. Connect a 12-15 VDC voltage source capable of supplying at least 850 milli-amps to the “**DC IN/OUT**” jack on the **MFJ-4117 Bias-Tee**. This is your DC voltage input connector.
3. Connect the “**RF/DC OUT/IN**” coaxial connector on the **MFJ-4117 Bias-Tee** to the **TRANSMITTER** connector on the **MFJ-994BRT Intellituner** using 50-ohm coaxial cable. The **MFJ-994BRT Intellituner** will recover the RF and DC signals.
4. Connect your coax-fed antenna to the **ANTENNA** connector using a 50-ohm coaxial cable, or connect your random wire to the **WIRE** binding post.
5. Connect your ground connection to the **GROUND** post.
6. Key your transmitter to output a carrier of 2-20 watts CW, FM or AM. The SWR should be auto-tuned to less than 1.5:1. This can be verified with an external SWR meter if desired.

Note: *If an amplifier is in-line, it should always be bypassed prior to tuning.*

7. You are now ready to transmit at full power.

Note: *During the automatic tuning process, the tuner will make some noise. These are the relays switching at a very high rate and is normal. Do not be alarmed.*

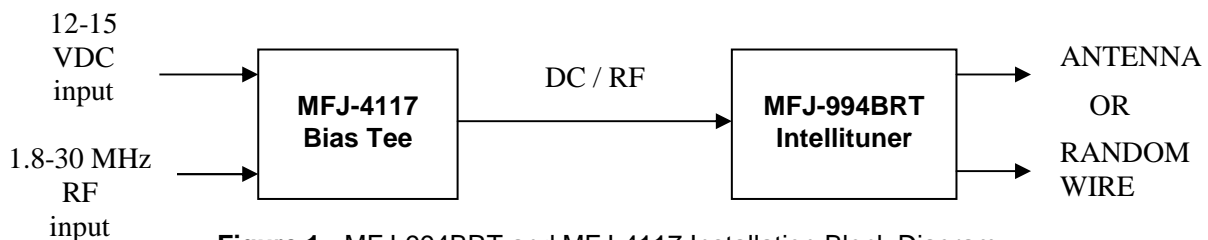

Figure 1: MFJ-994BRT and MFJ-4117 Installation Block Diagram

Note: To use the Random WIRE binding post, make sure to remove the antenna, if any, from the ANTENNA connector.

Internal Components

The MFJ-994BRT was designed for remote operation with no manual operation required. The tuning process starts automatically when the transmitter is keyed with at least two watts of power when the SWR is greater than 2:1. The MFJ-994BRT has been pre-set with default settings at the MFJ Factory. However, if you remove the unit from the box, you can change the default settings as well as verify proper operation of the unit. The following will guide you through the process. The control board is mounted upside down so will have to be unmounted before any changes are to be made.

- **C-UP and C-DN Buttons:** Used to manually increase or decrease the capacitance of the L-network matching circuit. The capacitance range is 0 to 2950 pF. The upper limit of capacitance, dependent on frequency, is restricted to limit the maximum voltage and current across the tuner's components.

Note: Pressing [C-UP] and [C-DN] simultaneously toggles the capacitor between the input and output sides of the L-network. Forward needle bounces to the 30-watt mark when the capacitor is on the transmitter side. Reflected needle bounces to the 5-watt mark when the capacitor is on the antenna side.

- **L-UP and L-DN Buttons:** Used to manually increase or decrease the inductance of the L-network matching circuit. The inductance range is 0 to 17 μ H. The upper limit of inductance, dependent on frequency, is restricted to limit the maximum voltage and current across the tuner's components.

Note: Pressing [C-DN] and [L-DN] simultaneously places the tuner in bypass mode. The reflected meter needle momentarily bounces to the 20-watt mark to indicate this. RF from the transmitter goes directly to the antenna with no matching.

- **AUTO Button:** Used to select automatic or semi-automatic tuning mode. Button *out* selects automatic mode – the tuning routine is automatically started when 2-20 watts of power is applied and the SWR is a preset amount above the preset target SWR.

Note: If an amplifier is in-line, it should always be bypassed prior to tuning.

- **TUNE Button:** Has three different functions based on the length of time you press and hold it before releasing. Press [TUNE] quickly (less than 0.5 second) to bypass the tuner. RF from the transmitter goes directly to the antenna with no matching.

Press and hold [TUNE] for 0.5-2 seconds to start the automatic tuning process. The transmitter must be keyed first with at least two watts of power. When the SWR is already below the target SWR, pressing [TUNE] will fine-tune the match for a lower SWR if possible. This function is not used in remote operation.

- **POWER Button:** Used to turn the power on and off. Note that during power-on the analog meter bounces four times to indicate the model 994. When the power is off, the tuner is bypassed (straight through from TRANSMITTER to ANTENNA and WIRE). When power is turned on, the tuner powers-up bypassed, but will revert to the last stored matching values or begin tuning on application of RF power when the TUNE button is pressed – or if Automatic or Sticky-Tune is enabled.

WARNING: Do not turn the power on and off rapidly, otherwise the tuning setting memory can be corrupted and the unit will have to be reset to factory defaults.

Note: During the tuning process, the tuner will make some noise. These are the relays switching at a very high rate and is normal. Do not be alarmed.

- **ANT Button:** Used in conjunction with other buttons for changing functions in the MFJ-994BRT.

Note: When the tuner power is OFF, the tuner is in bypass mode and RF from the transmitter goes directly to the antenna with no matching.

Connections

- **Transmitter:** SO-239 connector for coax cable from transmitter or transceiver. A MFJ-4117 bias tee is connected in-line between the transmitter output and this connector. This provides 12 volts DC on the coax to power the tuner. The MFJ-4117 is included with the MFJ-994BRT.
- **Antenna:** SO-239 connector for coax cable from antenna, or binding post for wire antennas. The **ANTENNA** connector is internally connected to the **WIRE** binding post.

Note: When using the **ANTENNA** connector, make sure to remove the wire antenna, if any, from the **WIRE** binding post.

- **Ground:** Wing-nut terminal for RF ground wire connection.
- **Wire:** Binding post for connecting single wire antennas. Notice the **WIRE** binding post is internally connected to the **ANTENNA** connector.

Note: When using the **WIRE** binding post, make sure to remove the antenna, if any, from the **ANTENNA** connector.

Installation

WARNING

- **Never operate the tuner with its cover removed. Contact with the components inside the tuner while transmitting will result in painful RF burns.**
- **Locate the tuner so that the terminals are *not accessible* during operation. The single wire connection may have high voltage while transmitting.**
- **Disconnect all antennas from the tuner during lightning storms.**
- **Always tune with low power (2-10 watts). Apply maximum power only after tuning up.**
- **Never exceed tuner specifications.**
- **Do not transmit with a high SWR for extended periods of time.**

1. Place the tuner in a convenient location at the operating position using the mounting holes provided. With a random wire, the WIRE terminal may have high RF voltages present. These voltages can cause serious RF burns if the terminal is touched when transmitting. **Be sure to locate the tuner so this terminal cannot accidentally be contacted during operation.**
2. Install the MFJ-4117 Bias-Tee between the transmitter and the antenna. Use a 50-ohm coaxial cable (such as RG-58) to connect the transmitter. See Figure 1.
3. Connect the transmitter to the “**RF IN/OUT**” coaxial connector on the **MFJ-4117 Bias-Tee** using a 50-ohm coaxial cable. (See Figure 1) This is the RF signal input connector.
4. Connect a 12-15 VDC voltage source capable of supplying at least 750 milli-amps to the “**DC IN/OUT**” jack on the **MFJ-4117 Bias-Tee**. This is your DC voltage input connector.
5. Connect the “**RF/DC OUT/IN**” coaxial connector on the **MFJ-4117 Bias-Tee** to the **TRANSMITTER** connector on the **MFJ-994BRT Intellituner** using 50-ohm coaxial cable. The **MFJ-994BRT Intellituner** will recover the RF and DC signals.
6. Connect your coax-fed antenna to the **ANTENNA** connector using a 50-ohm coaxial cable, or connect your random wire to the **WIRE** binding post.
7. Connect your ground connection to the **GROUND** post.
8. Key your transmitter to output a carrier of 2-10 watts CW, FM or AM. If desired, an external SWR/Wattmeter can be used to verify a tuned SWR of 1.5 or less before increasing RF power.
9. You are ready to transmit.
 - If too much power is applied when tuning, tuning will cease and the tuner will go into the bypass mode. This occurs when the forward power exceeds 75 watts and the SWR is greater than 3.0, or when the forward power exceeds 125 watts regardless of the SWR.
 - If more than 200 watts is applied to the tuner, the tuner will go into bypass mode.
 - Random wire and coax antennas must not be connected simultaneously to the WIRE and coax connectors on the tuner.

Note: Route all random wire antennas safely to prevent RF burn hazard.

Miscellaneous

Antenna Memory

The “memory resolution” is the width of frequency spectrum that the tuner recognizes as being the same as a tuned frequency already in memory. The memory resolution is approximately 0.1 percent of the lower frequency of each amateur band. For example, the memory resolution on the 40-meter band (7000 to 7300 kHz) is 7 kHz; if the tuner has memorized a setting for 7050 kHz, it will automatically call up this setting for any frequency from 7047 to 7053 kHz. Memory resolution is smaller at lower frequency to accommodate the higher antenna Q and larger at higher frequency where the antenna Q is lower. The memory resolutions for the HF amateur bands 160 through 10 meters are:

Meter	Frequency Range (kHz)	Memory Resolution (kHz)
160	1800 – 2000	2
75/80	3500 – 4000	4
60	5330.5, 5346.5, 5366.5, 5371.5 and 5403.5	5 memory locations
40	7000 – 7300	7
30	10100 – 10150	10
20	14000 – 14350	14
17	18068 – 18168	18
15	21000 – 21450	21
12	24890 – 24990	25
10	28000 – 29700	28

Table 1. Memory Resolution.

The memory resolution for non-amateur frequency bands between 160 and 10 meters is approximately 0.2 percent of the lower frequency of each band. There are over 2500 memory locations.

IntelliTune™ Algorithm

When the tuner cannot find an appropriate setting in its memory, it begins its calculation function. It measures the complex impedance of the antenna (load) at the transmitting frequency, then it calculates the LC components needed for a match. Then it fine-tunes the components for minimum SWR. If the tuner cannot calculate the load impedance, it proceeds to an adaptive search algorithm for tuning.

LC Limits

The upper limits of inductance (L) and capacitance (C) are factory-limited according to frequency and maximum power rating; i.e., higher frequencies need less inductance and less capacitance when the L-network is properly tuned. These limits are built into the MFJ-994BRT to prevent matching of extreme load impedance outside the tuner’s specification, which may result in excess voltage and/or current across the tuner’s components.

Morse Code (Only available when the MFJ-994BRT cover is removed)

If not enough power is applied for tuning (less than two watts); “QRO” (dah-dah-di-dah di-dah-dit dah-dah-dah) will be sent on CW. Increasing the input power above two watts ends this message.

When input power is too high, the tuner enters a self-protection mode by bypassing the tuner. The tuner will not allow any of its relays to change. This feature prevents damage to your tuner.

If too much power is applied when tuning, the tuner will cease the tuning routine and send “QRP” (dah-dah-di-dah di-dah-dit di-dah-dah-dit) on CW. This occurs when the forward power exceeds 75 watts and the SWR is greater than 3.0, or when the forward power exceeds 125 watts regardless of the SWR.

If more than 200 watts is applied to the tuner, the tuner will go into bypass mode and send “QRT” (dah-dah-di-dah di-dah-dit dah) on CW.

If the tuning process is activated under these conditions, the tuner will not start the tuning. It will send the appropriate code on CW.

The following table shows the various tuner Flashes:

Function	Indicates By One Flash			Indicates By Two Flashes			By Pressing
Antenna	1			2*			[ANT] < 1 second
Memory Bank	Bank A (1 Beep)	Bank B* (2 Beep)	Bank C* (3 Beep)	Bank D* (4 Beep)	Off (5 Beep)		[ANT] > 1 second
Bypass Toggle	Bypass Mode (L = 0 and C = 0)			Restore Last L/C Setting			[TUNE] < 0.5 sec.
Tuned SWR	SWR ≤1.5 (1 Beep)	SWR ≤2.0 (2 Beep)	SWR ≤2.5 (3 Beep)	SWR ≤3.0 (4 Beep)	SWR >3.0 ("SWR")		[TUNE] for 0.5 to 2 seconds
StickyTune	On			Off			[TUNE] > 2 seconds
Tuning Mode	Automatic			Semi-Automatic			[TUNE] + [ANT]

* Not available on the MFJ-994BRT

Table 2. Tuner Beep.

Foldback Circuit

Modern transceivers with solid-state finals usually have a foldback circuit to protect the final transistors from high SWR. A foldback circuit detects the SWR during transmit and reduces the output power as the SWR rises above a preset threshold, usually 2:1. The higher the SWR the lower the power is set to prevent damage.

If your transceiver has a foldback circuit, you can simply key down and tune at any power level from 2 to 100 watts. If your transceiver does not have a foldback circuit, you must manually set the power level to 20 watts or less for tuning (2-10 watts recommended). At higher power levels, the reflected power occurring during tuning can damage your transceiver and causes component arcing which can damage the relays in the tuner.

Check your transceiver owner's manual to see if your transceiver has a foldback circuit.

Grounding Hints

To minimize RFI, single wire feedlines (such as used with Windom or longwire antennas) should be kept away from other wiring. Radiation will be minimized if the single wire feeder runs parallel and reasonably close to the wire that connects the tuner to the outdoor ground. The antenna feed wire should be adequately insulated to prevent arcing or accidental contact.

CAUTION

For operator safety, a good outside earth ground or water pipe ground should always be installed and connected to the case of the MFJ-994BRT. Make certain the safety ground also connects to the transmitter and other station accessories. A wing-nut post marked GROUND is provided for ground connections.

For safety, please use good DC and RF grounds. It is particularly important to have a good RF ground when using a single wire feeder. When using a single wire feeder, the tuner needs something to "push" against in order to force current into the single wire feedline. If a good RF ground is not available, RF will usually find its way back into the power line (RFI), transmitter audio circuits (RF feedback), or the operator (RF burns).

Metal water pipes and ground rods provide good DC and AC safety grounds, but they are often inadequate for RF grounding. Ground rods by themselves are almost useless for dependable RF grounding.

RF grounds work much better when "spread out" over a large area, especially when they employ multiple connections directly to the equipment ground point. Metal water pipes, heating ducts, and fences may work (especially if they are connected together with multiple wires), but the best RF grounds are radial systems or multi-wire counterpoises. Radials and counterpoises provide large, low resistance surfaces for RF energy.

RF and lightning travel on the surface of conductors. Braided or woven conductors have high surface resistance to lightning and RF. Ground leads for RF and lightning should have wide smooth surfaces. Avoid the use of woven or braided conductors in RF and lightning grounds unless the lead needs to be flexible.

Antenna System Hints

Location

For the best performance, an end-fed longwire wire antenna should be at least one quarter-wavelength long at the operating frequency. Horizontal dipole antennas should be at least a half-wavelength long and located as high and clear as possible. While good RF grounds help the signal in almost any transmitting installation, it is extremely important to have good RF grounds with long wire or other Marconi-style antennas.

Matching Problems

Most matching problems occur when the antenna system presents an extremely high impedance to the tuner. When the antenna impedance is much lower than the feedline impedance, an *odd quarter-wavelength* feedline converts the low antenna impedance to a very high impedance at the tuner. A

similar problem occurs if the antenna has an extremely high impedance and the transmission line is a multiple of a half-wavelength. The half-wavelength line *repeats* the very high antenna impedance at the tuner. Incorrect feedline and antenna lengths can make an otherwise perfect antenna system very difficult or impossible to tune.

One example where this problem occurs is on 80 meters when an odd quarter-wave (60 to 70 feet) open wire line is used to feed a half-wave (100 to 140 feet) dipole. The odd quarter-wave line transforms the dipole's low impedance to over three thousand ohms at the tuner. This is because the mismatched feedline is an *odd multiple* of 1/4 wavelength long. The line *inverts* (or teeter-totters) the antenna impedance.

A problem also occurs on 40 meters with this same antenna example. The feedline is now a multiple of a half-wave (60 to 70 feet) and connects to a full-wave high impedance antenna (100 to 140 feet). The half-wave line repeats the high antenna impedance at the tuner. The antenna system looks like several thousand ohms at the tuner on 40 meters.

This places enormous strain on the tuner components, since voltages can reach several thousand volts. This can cause component arcing and heating.

The following suggestions will reduce the difficulty in matching an antenna with a tuner:

- Never center feed a half-wave multi-band antenna with a high impedance feedline that is close to an odd multiple of a quarter-wave long.
- Never center feed a full-wave antenna with a feedline close to a multiple of a half-wave long.
- If this tuner will not "tune" a multi-band antenna, add or subtract 1/8 wave of feedline (for the band that won't tune) and try again.
- Never try to load a G5RV or center fed dipole on a band below the half-wave design frequency. If you want to operate an 80-meter antenna on 160 meters, feed either or both conductors as a longwire against the station ground.

To avoid problems matching or feeding any dipole antenna with high impedance open wire lines, avoid the following lengths.

160 meters dipole: Avoid 130, 260 ft
80 meters dipole: Avoid 66, 135, 190 ft
40 meters dipole: Avoid 32, 64, 96, 128 ft

Some slight trimming or adding of feedline may be necessary to accommodate the higher bands.

WARNING

To avoid problems, a dipole antenna should be a full half-wave on the lowest band. On 160 meters, an 80 or 40 meters antenna fed the normal way will be extremely reactive, with only a few ohms of feedpoint resistance. Trying to load an 80 meters half-wave dipole (or shorter) antenna on 160 meters can be a disaster for both your signal and the tuner. The best way to operate 160 meters with an 80 or 40 meters antenna is to load either or both feedline wires (in parallel) as a longwire. The antenna will act like a "T" antenna worked against station ground.

Appendices

POWER-ON OPERATIONS			
(Press and hold buttons while turning on the power.)			
Press and hold	C-UP	+	POWER to get the firmware version number.
Press and hold	L-UP	+	POWER to start the self test.
Press and hold	C-DN	+	POWER to test the relays.
Press and hold	L-DN	+	POWER to test the power-down circuitry.
Press and hold	C-UP + C-DN	+	POWER to calibrate the wattmeter.
Press and hold	C-UP + L-UP	+	POWER to calibrate the SWR bridge.
Press and hold	C-DN + L-DN	+	POWER to calibrate the frequency counter.
Press and hold	TUNE + C-DN	+	POWER to delete the antenna memory.
Press and hold	TUNE + L-DN	+	POWER to reset factory defaults.
Press and hold	TUNE + C-DN + L-DN	+	POWER to perform total reset.

Figure 10. Power-On Operations.

Firmware Version Number

Make sure the meter is calibrated. To obtain the firmware version number, press and hold the [C-UP] button while turning the power on. The version number X.YY is represented by the meter forward needle for X (forward reading \div 10) and the reflected needle for YY (reflected reading). For example, forward needle on 20-watt mark and reflected needle on 2-watt mark represent firmware version number 2.02. Release button to resume normal operation.

Resetting the Tuner

Each time the tuner is powered off, the microprocessor saves all memories and configurations to non-volatile memory. If the tuner is not working properly, even on initial power on, try resetting to the factory defaults.

Factory Defaults

The unit is shipped with the following default settings:

- Inductance 0 μ H
- Capacitance 0 pF on transmitter side
- Target SWR 1.5
- Auto Tune SWR 0.5 above target SWR

- Memory Bank A
- Meter Range 3000 watts (high range)
- Sticky-Tune Off (Always resets to OFF when the power is cycled and after tuning)

Note: *Resetting to factory defaults does not erase the antenna memories.*

To reset the tuner to these defaults:

1. Turn off the power to the tuner.
2. Press and hold *both* the [TUNE] and [L-DN] buttons while turning the power on.
3. Release the buttons when both meter needles read full scale.
4. Resume normal operation.

WARNING: If the MFJ-994BRT is not behaving normally or acting erratic, try resetting the tuner to factory defaults.

Delete Antenna Memory

To delete the antenna memory, turn off power to the tuner, and then press and hold *both* the [TUNE] and [C-DN] buttons while turning the power back on. Both meter needles will read half scale. Press the [C-UP] button to delete the antenna memory (both meter needles go to full scale), or press the [L-UP] button to cancel (both meter needles go to zero scale). Release the button to resume normal operation. Remember that the antenna memory will be lost!

Total Reset

To erase the antenna memory and reset to factory defaults, press and hold down the [TUNE], [C-DN] and [L-DN] buttons while turning the power on. Both meter needles will read half scale. Press the [C-UP] button for a total reset (both meter needles go to full scale), or press the [L-UP] button to cancel (both meter needles go to zero scale). Release the button to resume normal operation. Remember that all antenna memories will be lost and tuner settings will return to default!

Self Test

A self-test routine checks the functions of the tuner. This routine checks the meter, the front-panel buttons, and the internal memory. During the self-test, you may stop the test by turning off the unit; however, this should NOT be done during the memory test or the memory could be corrupted. The self-test can be completed in approximately 30 seconds.

This test also can be used to test the MFJ-994RC Remote Control. Make sure to lock in the [AUTO] button on the tuner before starting the self-test, and press the buttons on the MFJ-994RC instead of the front-panel buttons when prompted.

Note: Performing the self-test will reset the unit to its factory default settings.

Here is the self-test procedure:

1. Turn off the power to the tuner, and press all buttons to the *out* position.
2. Unplug the radio interface cable, if one is connected, from the tuner.
3. If testing the MFJ-994RC Remote Control, connect it to the Remote Port and make sure the [AUTO] button *on the tuner* is locked in.
4. Press and hold *only* the [L-UP] button while turning the power on.
5. The test begins by the forward needle of the meter going up slowly to full scale and then drops to zero, followed by the reflected needle going up slowly to full scale and then dropping to zero. This tests the meter. Release the [L-UP] button before the reflected needle goes to zero.
6. The reflected needle goes to the 3-watt mark. Now, press each of the front panel buttons in this sequence: [C-UP], [C-DN], [L-UP], [L-DN], [AUTO], and then [TUNE]. The forward needle should bounce once for each press, and the reflected needle should move up a division for each press.

7. The unit then tests its non-volatile memory. This will reset the unit to its factory default settings.
8. If the unit is okay, both meter needles will go to full scale. If there is a problem, the forward needle will bounce and the reflected needle mark will indicate the failure.
9. Turn the tuner power off.

Failure Message	Reflected Needle (watts)	Indicates
C-UP FAIL	3	[C-UP] button is shorted or improperly connected.
C-DN FAIL	4	[C-DN] button is shorted or improperly connected.
L-UP FAIL	5	[L-UP] button is shorted or improperly connected.
L-DN FAIL	7.5	[L-DN] button is shorted or improperly connected.
AUTO FAIL	10	[AUTO] button is shorted or improperly connected.
TUNE FAIL	15	[TUNE] button is shorted or improperly connected. Radio interface cable is connected but radio power is off.
MEMORY FAIL	20	Non-volatile memory circuitry is improperly connected.
WAKEUP FAIL	30	Microprocessor wakeup circuitry problem.
PD FAIL	40	Power down circuitry problem.

Table 4. Failure Messages.

Power-Down Circuit Test

When the 12 VDC power to the tuner is turned off, the tuner saves all settings to non-volatile memory. The Power-Down Circuit Test checks the power-down detection circuitry. It is recommended that this test be done immediately after the regular self-test described above.

Note: The tuner must be reset to factory defaults before performing this test.

Here is the test procedure:

1. Make sure power to the tuner is off.
2. If the tuner has been reset to factory defaults, skip to step 6; otherwise continue with step 3.
3. Press and hold *only* the [ANT] button while turning the power on. Both LEDs will blink until the button is released.
4. Within four seconds of releasing [ANT], press the [TUNE] button once.
5. After releasing [TUNE] for four seconds, Flash three times and turn the power off.
6. Press and hold *only* the [ANT] button while turning the power on. Both LEDs will blink until the button is released.
7. Within four seconds of releasing [ANT], press the [TUNE] button four times.
8. After releasing [TUNE] for four seconds and if the power-down detection circuitry is okay, a repetitive message "PASS" will be sent in Morse code (di-dah-dah-dit di-dah di-di-dit di-di-dit) by blinking the green LED. If there is a problem, message "PD FAIL" will be sent in Morse code repetitively and the red LED will blink.
9. Turn the power off.

Relay Test

WARNING: Turn off the transmitter power or disconnect the transmitter before performing this test; otherwise, damage to the tuner can result.

WARNING: Turn off the transmitter power or disconnect the transmitter before performing this test; otherwise, damage to the tuner can result.

To test the relays and their control circuitry, press and hold the [C-DN] button while turning the power on. Both meter needles will bounce. Release the button. The relays are tested in groups of four as shown in the table below. The [C-UP], [L-UP], [C-DN] and [L-DN] buttons are used to toggle each relay in each group of four. Press button to engage the relay and release it to disengage the relay. Listen for relay clicks. Press the [TUNE] button to proceed to the next group of four relays. There are 18 relays in the tuner. Repeat the above procedure to test all the relays. Normal operation is resumed after this test. The reflected power needle indicates which group of relays is being checked as follows:

[C-UP]	[L-UP]	[C-DN]	[L-DN]
1	Not used	3	4
5	6	7	8
9	10	11	12
13	14	15	16
17	18	19	Keys Radio Interface

Since there are no relays #2 and #20, pressing the [L-UP] button in the first group and the last button [L-DN] in the last group will not produce a click.

Frequency Counter Calibration

Frequency Counter Calibration

To calibrate the frequency counter, you will need a transmitter, a 50-ohm dummy load, two 50-ohm SO-239 coax cables, a Phillips screwdriver, and a tuning tool or small flat blade screwdriver.

WARNING: Do not touch anything inside the tuner during operation! Serious, painful RF burns can result.

WARNING: Never operate the MFJ-994B with its cover removed; dangerous voltages and currents can be present during operation. Never exceed tuner specifications.

1. Turn off the power to the tuner and the transmitter.
2. Remove the cover from the tuner (12 screws) with a Phillips screwdriver.
3. Connect the 50-ohm dummy load to the ANTENNA connector; connect the transmitter to the TRANSMITTER connector on the tuner.
4. Turn on the power to the transmitter. Set and lock the transmitter frequency to *exactly* 29.000 MHz.
5. Press and hold *both* the [C-DN] and [L-DN] buttons while turning the tuner power on. Both meter needles will go to full scale.
6. Key the transmitter to output about 10 watts. Adjust trimmer capacitor C118 (located between the two big integrated circuits) until the tuner's meter needles settle at the 0-watt marks. Notice the meter movement is exaggerated for easier calibration. Nominal tolerance of the frequency counter is ± 1 kHz.
7. Turn off the power to the tuner and the transmitter.

8. Secure the cover back onto the tuner.

SWR Bridge Calibration

To calibrate the SWR Bridge, you will need a transmitter capable of 100 watts output, a precise calibrated wattmeter, a 50-ohm dummy load, three 50-ohm SO-239 coax cables, a Phillip screwdriver, and a tuning tool or small flat blade screwdriver. Make sure the tuner's meter is calibrated.

WARNING: Do not touch anything inside the tuner during operation! Serious, painful RF burns can result.

WARNING: Never operate the MFJ-994B with its cover removed; dangerous voltages and currents can be present during operation. Never exceed tuner specifications.

Note: The trimmers involved in this calibration are located on the main circuit board in front of the TRANSMITTER connector; do not confuse these with the SWR/wattmeter trimmers.

1. Turn off the power to the tuner and the transmitter.
2. Remove the cover from the tuner (12 screws) with a Phillips screwdriver.
3. Connect the 50-ohm dummy load to the ANTENNA connector; connect the wattmeter between the transmitter and the TRANSMITTER connector on the tuner.
4. Turn on the power to the transmitter. Select a frequency in the middle of an HF band, such as 7.253 MHz, for calibration.
5. Press and hold *both* the [C-UP] and [L-UP] buttons while turning the tuner power on. Both meter needles will bounce. Release the buttons.
6. Key the transmitter to output 100 watts and adjust the trimmer capacitor C91 for minimum reflected power. Notice the reflected meter movement is exaggerated for easier calibration.
7. Key the transmitter to 100 watts output and adjust the FWD trimpot R72 until the forward power needle indicates 100-watt mark.
8. Press the [TUNE] button and observe that the reflected power needle goes to full scale.
9. Turn off the transmitter and reverse the ANTENNA and TRANSMITTER connections; that is, connect the 50-ohm dummy load to the TRANSMITTER connector and connect the transmitter/wattmeter to the ANTENNA connector.
10. Turn on the transmitter's power.
11. Key the transmitter to 100 watts output and adjust the REF trimpot R71 until the forward power needle (yes, the forward needle) indicates 100-watt mark; the reflected meter should be at full scale.
12. Press the [TUNE] button to end calibration.
13. Turn off the power to the tuner and the transmitter.
14. Remove the transmitter/wattmeter and the 50-ohm dummy load from the tuner.
15. Secure the cover back onto the tuner.
16. Connect your transmitter to the TRANSMITTER connector and connect your antenna to the appropriate antenna connector on the tuner.

In Case of Difficulty

If the tuner acts erratic, reset the tuner to factory defaults.

If the tuner fails to tune, please **double check** all connections and follow the tuning procedures again.

If the tuner arcs at the rated power levels, please **double check** all connections and follow the tuning procedures again. Ensure you are not exceeding the tuner's rated power handling capability.

Note: If the tuner arcs when operating on the 160-meter band, it may be necessary to reduce transmitter output power.

If you are still unsuccessful, but the tuner does adjust and operate when used with a dummy load or another antenna, please read "Grounding Hints" and "Antenna System Hints" on page 13.

Technical Assistance

If you have any problem with this unit first check the appropriate section of this manual. If the manual does not reference your problem or your problem is not solved by reading the manual, you may call *MFJ Technical Service* at 662-323-0549 or the *MFJ Factory* at 662-323-5869. You will be best helped if you have your unit, manual and all information on your station handy so you can answer any questions the technicians may ask.

You can also send questions by mail to MFJ Enterprises, Inc., 300 Industrial Park Road, Starkville, MS 39759; by facsimile (FAX) to 662-323-6551; or by email to techinfo@mfjenterprises.com. Send a complete description of your problem, an explanation of exactly how you are using your unit, and a complete description of your station. Also include the firmware version number of your unit.

List of Accessories

- **MFJ-1312D:** 12 VDC 500mA power supply
- **MFJ-4117:** BiasTee DC power injector with on/off switch (included with the MFJ-994BRT)
- **MFJ-5803:** 3 feet long RG-58 A/U 50-ohm coax cable with a PL-259 connector on each end
- **MFJ-5806:** 6 feet long RG-58 A/U 50-ohm coax cable with a PL-259 connector on each end
- **MFJ-5818:** 18 feet long RG-58 A/U 50-ohm coax cable with a PL-259 connector on each end

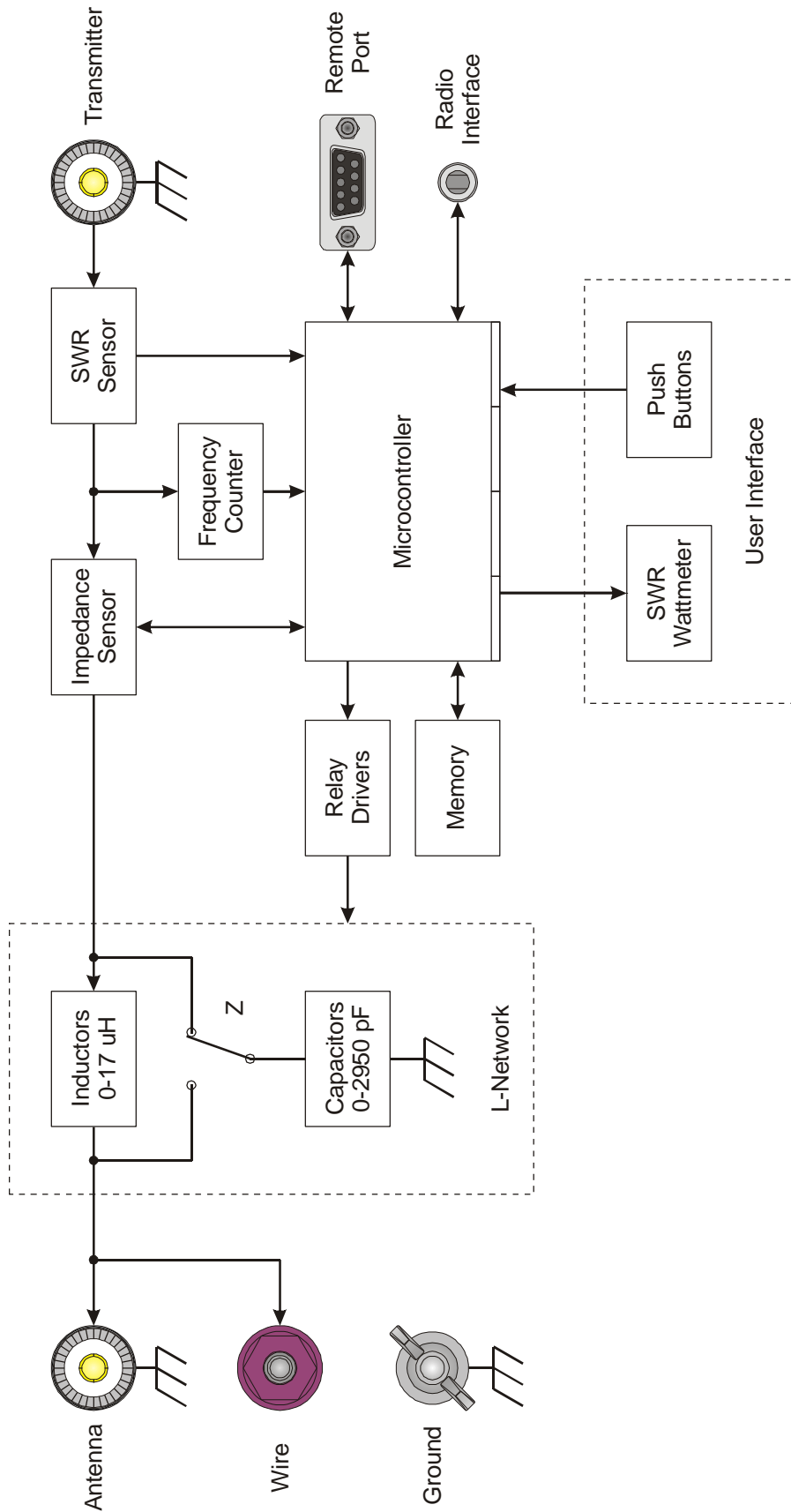

Figure 11. MFJ-994B Circuit Block Diagram.

FULL 12-MONTH WARRANTY

MFJ Enterprises, Inc. warrants to the original owner of this product, if manufactured by MFJ Enterprises, Inc. and purchased from an authorized dealer or directly from MFJ Enterprises, Inc. to be free from defects in material and workmanship for a period of 12 months from date of purchase provided the following terms of this warranty are satisfied.

1. The purchaser must retain the dated proof-of-purchase (bill of sale, canceled check, credit card or money order receipt, etc.) describing the product to establish the validity of the warranty claim and submit the original or machine reproduction of such proof of purchase to MFJ Enterprises, Inc. at the time of warranty service. MFJ Enterprises, Inc. shall have the discretion to deny warranty without dated proof-of-purchase. Any evidence of alteration, erasure, or forgery shall be cause to void any and all warranty terms immediately.
2. MFJ Enterprises, Inc. agrees to repair or replace at MFJ's option without charge to the original owner any defective product provided the product is returned postage prepaid to MFJ Enterprises, Inc. with a personal check, cashiers check, or money order for **\$10.00** covering postage and handling.
3. MFJ Enterprises, Inc. will supply replacement parts free of charge for any MFJ product under warranty upon request. A dated proof of purchase and a **\$8.00** personal check, cashiers check, or money order must be provided to cover postage and handling.
4. This warranty is **NOT** void for owners who attempt to repair defective units. Technical consultation is available by calling (662) 323-5869.
5. This warranty does not apply to kits sold by or manufactured by MFJ Enterprises, Inc.
6. Wired and tested PC board products are covered by this warranty provided **only the wired and tested PC board product is returned**. Wired and tested PC boards installed in the owner's cabinet or connected to switches, jacks, or cables, etc. sent to MFJ Enterprises, Inc. will be returned at the owner's expense unrepai red.
7. Under no circumstances is MFJ Enterprises, Inc. liable for consequential damages to person or property by the use of any MFJ products.
8. **Out-of-Warranty Service:** MFJ Enterprises, Inc. will repair any out-of-warranty product provided the unit is shipped prepaid. All repaired units will be shipped COD to the owner. Repair charges will be added to the COD fee unless other arrangements are made.
9. This warranty is given in lieu of any other warranty expressed or implied.
10. MFJ Enterprises, Inc. reserves the right to make changes or improvements in design or manufacture without incurring any obligation to install such changes upon any of the products previously manufactured.
11. All MFJ products to be serviced in-warranty or out-of-warranty should be addressed to **MFJ Enterprises, Inc., 300 Industrial Park Rd, Starkville, Mississippi 39759, USA** and must be accompanied by a letter describing the problem in detail along with a copy of your dated proof-of-purchase and a telephone number.
12. This warranty gives you specific rights, and you may also have other rights, which vary from state to state.