

DCU-2
Digital Antenna Rotator Controller
For the
HAM-IV and T-2X
Series Rotators

Instruction Manual

hy-gain[®]
308 Industrial Park Road
Starkville, MS 39759
USA

This information is believed correct, but no warranty is given or implied and no liability is assumed by **hy-gain** as to its accuracy or completeness. Changes may be made from time to time so the user should verify all factors that may be critical.

This information is not to be construed as to authorizing or advising use of any patented invention or any computer software.

hy-gain® 12-MONTH LIMITED WARRANTY

hy-gain warrants to the original owner of this product, if manufactured by **hy-gain** and purchased from an authorized dealer or directly from **hy-gain** to be free from defects in material and workmanship for a period of 12 months from date of purchase provided the following terms of this warranty are satisfied.

1. The purchaser must retain the dated proof-of-purchase (bill of sale, canceled check, credit card or money order receipt, etc.) describing the product to establish the validity of the warranty claim and submit the original or machine reproduction of such proof-of-purchase to **hy-gain** at the time of warranty service. **hy-gain** shall have the discretion to deny warranty without dated proof-of purchase. Any evidence of alteration, erasure, or forgery shall be cause to void any and all warranty terms immediately.
2. **hy-gain** agrees to repair or replace at **hy-gain**'s option without charge to the original owner any defective product under warranty, provided the product is returned postage prepaid to **hy-gain** with a personal check, cashiers check, or money order for \$12.00 covering postage and handling.
3. Under no circumstances is **hy-gain** liable for consequential damages to person or property by the use of any **hy-gain** products.
4. Out-of-warranty Service: **hy-gain** will repair any out-of-warranty product provided the unit is shipped prepaid. All repaired units will be shipped COD to the owner. Repair charges will be added to the COD fee unless other arrangements are made.
5. This warranty is given in lieu of any other warranty expressed or implied.
6. **hy-gain** reserves the right to make changes or improvements in design or manufacture without incurring any obligation to install such changes upon any of the products previously manufactured.
7. All **hy-gain** products to be serviced in-warranty or out-of-warranty should be addressed to:

hy-gain®
308 Industrial Park Road,
Starkville, Mississippi
39759, USA

and must be accompanied by a letter describing the problem in detail along with a copy of your dated proof-of-purchase.

8. This warranty gives you specific rights, and you may also have other rights which vary from state to state

DCU-2 Digital Antenna Rotator Controller

Table of Contents

Section 1 DCU-2 Digital Antenna Rotator Controller.....	1
DCU-2 Digital Control Unit Specifications:.....	1
Section 2 Precautions.....	2
Section 3 Wiring and Check-Out.....	2
Using Existing Cable	2
New or Replacement Control Cable	2
Attaching Contacts to Wires and Connector.....	3
Section 4 Setup of the DCU-2 Control	5
Setup	5
Rotator Installation Precautions.....	6
Section 5 Operation of DCU-2	7
Manual Operation	7
MANUAL ROTATION.....	7
HEADING SET	7
Computer Operation.....	7
RS-232 Input.....	7
USB Input	7
Software Control.....	8
COMMAND SET	8
Menu Items	9
Menu Function Details.....	10
OFFSET	10
BRAKE DELAY	10
COAST SET	10
CALLSIGN.....	10
NORTHSTOP	10
SLEEP DELAY	10
REVERSE LCD.....	10
Section 6 Troubleshooting	11
Wiring.....	11
Antenna Motion.....	11
Lack of Power.....	11
Checking the Control Unit Voltages.....	13
Checking the Rotator Resistances.....	13
Heading Notes.....	13
Section 7 DCU-2 Control Unit Block Diagram.....	14
Section 8 DCU-2 Printed Circuit Board	16
How to Get Factory Service.....	20

DCU-2 Digital Antenna Rotator Controller

Figures

Figure 1	Front Panel.....	1
Figure 2	Back Panel.....	1
Figure 3	Control Cable Connector Attachments	3
Figure 4	Attaching Contacts to Wires and Connectors.....	4
Figure 5	LCD Display.....	5
Figure 6	RS-232 Wiring Guide.....	8
Figure 7	Command Set	8
Figure 8	DCU-2 Block Diagram.....	14
Figure 9	DCU-2 PCB Schematic Diagram	16

Tables

Table 1	Wire Color List.....	2
Table 2	Maximum Wire Length	3
Table 3	Recommended Control Cables	3
Table 4	Troubleshooting Chart	12
Table 5	Voltage Readings.....	13
Table 6	Rotator Resistance Chart	13
Table 7	DCU-2 Chassis Parts	14
Table 8	DCU-2 PC Board Parts	17
Table 9	Connector Parts Pack PN 870598.....	18
Table 10	DCU-2 120V Parts Pack.....	18
Table 11	DCU-2 240V parts Pack	18

Section 1 DCU-2 Digital Antenna Rotator Controller

The DCU-2 digital control unit features a Large LCD display indicating the beam heading, manual and computer controlled beam heading selection, manual rotation controls. Settings in memory include break delay, rotator coast control, North and South

center headings, adjustable sleep time, and call sign display.

You may use your existing cable, you may assemble your own cable from the information supplied in this manual, or you may purchase pre-assembled

DCU-2 Digital Control Unit Specifications:

Size.....4.125" x 8.5" x 9"
 Weight.....6.25 lbs. (2.84 Kg)
 Voltage.....120VAC or 240VAC (optional.)

Brake Delay0-8 seconds Default 3
 Coast Delay.....0-10 seconds Default 0
 Sleep Delay1-240 minutes or continuous ON Default 20

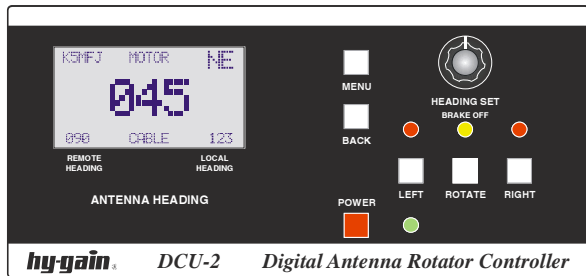

Figure 1 Front Panel

Front Panel Controls

POWER Power ON/OFF
LEFT Manually rotate left/CCW
RIGHT Manually rotate right/CW
HEADING SET Set the locally controlled antenna heading or bearing. Pushing in the "HEADING SET" selects any menu function selected or executes the menu function.
ROTATE Instructs the controller to rotate the antenna to the locally set heading.
MENU Displays the menu on the LCD screen.
BACK Backs out of any menu instruction without executing the instruction.

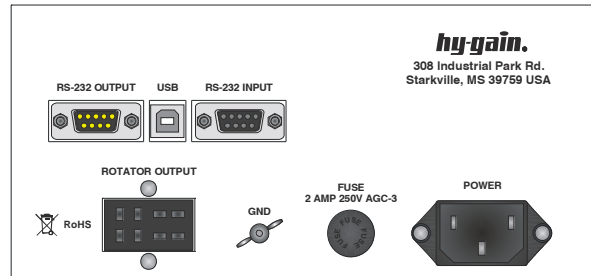

Figure 2 Back Panel

Back Panel Connections

RS-232 INPUT Input COM Port
GROUND Chassis ground
RS-232 OUTPUT Output loop through
FUSE Protective fuse
USB USB COM Port
ROTATOR OUT Rotator connections
POWER 120 VAC Input
 (240VAC Input optional)

Section 2 Precautions

Towers and antennas require caution during erection, placement, and maintenance! Extreme care must be taken during erection so that metal tower and antenna parts DO NOT contact power lines, be a hazard to individuals, or endanger property even if the parts slip, rotate, retract, fall or fracture!

Metal towers must be grounded properly at the tower location before the tower is erected. This is to minimize electrical hazard and the possibility of lightning damage. DO NOT bury bare aluminum wires or stakes in the ground. Use copper or copper-clad ground stakes. The service entrance ground should be

checked. The household electrical outlet should be the 3-prong type (grounded back to the service entrance).

The DCU-2 Control Unit is not weatherproof and must be located in a house or other protected location. Connect a ground wire to the 1/4"-20 terminal on the back of the DCU-2

The DCU-2 has been carefully designed and manufactured to give many years of trouble-free service when carefully and professionally installed. It consists of the strongest and best commercially available components. This product is manufactured in the U.S.A.

Section 3 Wiring and Check-Out

Using Existing Cable

1. If reusing the existing control cable write down the colors of the wires attached to your existing rotator control unit. Table 1 is provided for that purpose.

CAUTION:

The new connector may be numbered differently than the terminal strip. Pay close attention to the pin numbers! Your Cable color code may not match the color code listed in

Figure 3. Pay attention to the colors actually used. You may wish to check your wiring by measuring the rotator resistances as shown in Table 6 Rotator Resistance Chart.

New or Replacement Control Cable

1. If replacing the control cable or a new installation determine the length of control cable required and find the wire gauge (size) required from Table 2 Maximum Wire Length.
2. Assemble the rotator cable as shown in

Terminal	Color
1	
2	
3	
4	
5	
6	
7	
8	

Table 1 Wire Color List

3. Figure 3, or purchase a pre-assembled cable.

Maximum Length	Gauge for Terminals 1 & 2	Gauge for Terminals 3-8
125' (38 M)	#18 (1.19 mm)	#20 (0.97 mm)
200' (61 M)	#16 (1.42 mm)	#18 (1.19 mm)

DCU-2 Digital Antenna Rotator Controller

300' (91 M)	#14 (1.75 mm)	#16 (1.42 mm)
-------------	---------------	---------------

Table 2 Maximum Wire Length

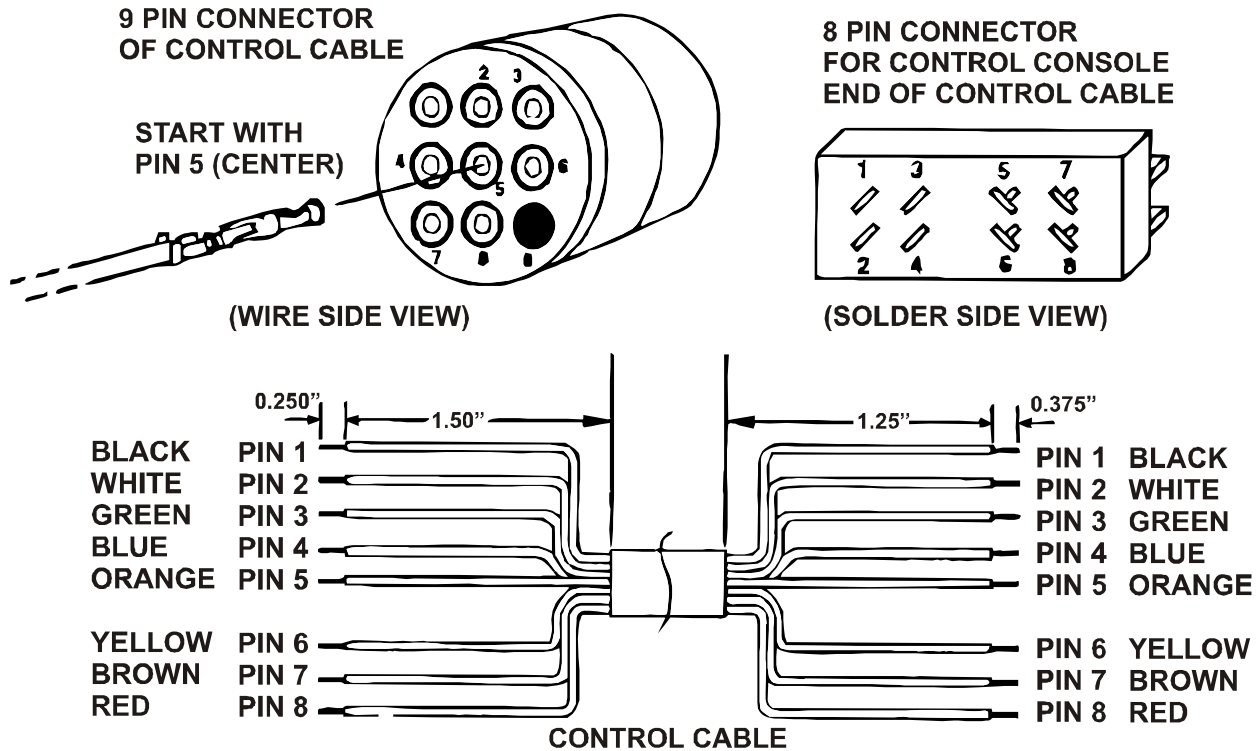

Figure 3 Control Cable Connector Attachments

**Belden 8448
Belden 9405
IEWC #8612**

Table 3 Recommended Control Cables

NOTE: The specifications call for heavier gauge wire in two locations. Leads #1 and #2 must be heavier gauge and less total lead resistance.

Attaching Contacts to Wires and Connector

Since these contacts will be inserted into connector blocks, their tabs must be carefully rounded. Unless you have a crimping tool for installing connectors, use the following procedure. See Figure 4.

Repeat for each contact. Pay close attention to the numbered holes in the connector! Pull back lightly on each conductor to be sure each contact is locked in each cavity.

CAUTION

Shorts between terminals or grounded leads may damage the rotator. Check the numbered pins on each connector with an Ohmmeter! Pin 1 is connected to pin 1, etc.

Once locked in place, the contacts may only be safely removed with an extraction tool. This tool consists of a tube with an OD of 0.129 and an ID of 0.115. When inserted over the contact from the front side, this tool compresses the locking tabs, permitting easy removal.

DCU-2 Digital Antenna Rotator Controller

1. CUT WIRES TO SPECIFIED LENGTH
REMOVE 1/8" OF INSULATION
FROM END.

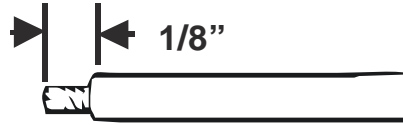

2. INSERT WIRE BETWEEN TABS
ON CONTACT

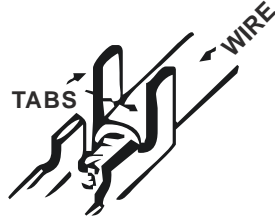

3. BEND TABS TIGHTLY AROUND
BARE WIRE END



4. BEND OPPOSITE TAB
AROUND FIRST TAB

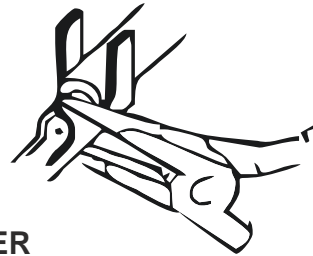

5. APPLY SOLDER. DO NOT ALLOW SOLDER
TO FLOW INTO CONTACT END,
HOLD CONTACT END UPWARD.

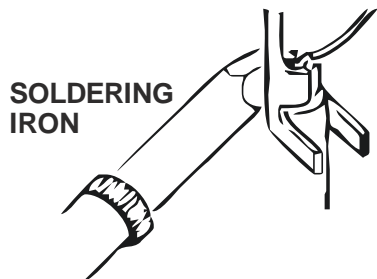

6. CAREFULLY SHAPE END TABS
AROUND INSULATION
ON THE WIRE



7. PUSH CONTACTS INTO HOLES
IN CONNECTOR SHELL UNTIL
CONTACT CLICKS INTO PLACE

CONNECTOR SHELL

SOCKET CONTACT

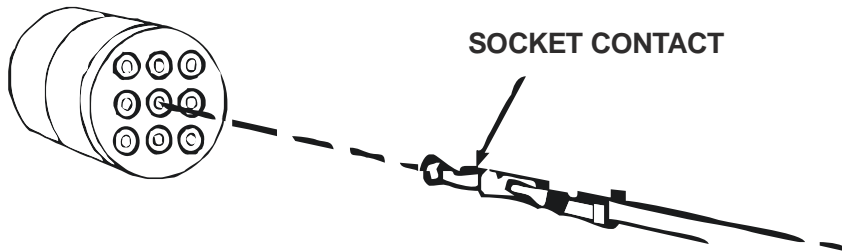

Figure 4 Attaching Contacts to Wires and Connectors

Section 4 Setup of the DCU-2 Control

Setup

1. With the rotator sitting in the upright position (either on the bench or on the tower) and connected to the control unit by the 8-wire cable, plug the control unit power cord into a receptacle.
2. The DCU-2 display should look similar to the display shown in Figure 5. The numeric display in the center indicates the current bearing of your rotator. The numeric display in the lower right corner indicates the target bearing that is manually set using the "HEADING SET" knob or "LOCAL HEADING". The numeric display in the lower left indicates target bearing that is computer set or "REMOTE HEADING". The character display in the upper right corner indicates the compass heading in "NESW" format. The alphanumeric display in the upper left corner is where the call sign is displayed if programmed. If the center display reads a steady "999", disconnect your control cable and check the cable wiring with an ohmmeter. See the section "Checking the Rotator Resistances from the Ground". Proceed if the cable checks OK. 999 also indicates that the cable may not be not plugged in.

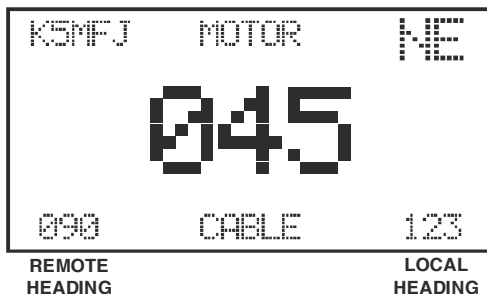

Figure 5 LCD Display

"MOTOR" is displayed when there is no indication of rotator movement and "CABLE" also indicates a cable problem.

3. If the current bearing display shows a number between "000" and "359", then proceed. Twist the HEADING SET knob. LOCAL HEADING display should change. Using the knob, select a target bearing at least 30 degrees from the current bearing. Push the "ROTATE" button. The brake in the rotator should release, the rotator will turn a few degrees in the opposite direction, reverse direction, and then turn to the target bearing. The rotator should turn to the heading plus or minus 3 or 5 degrees. The brake solenoid will "hum" for 3 seconds or what the menu brake setting was set to if changed, then the brake will engage. During rotation the display will show the actual heading as it turns. If operation does not work as described, immediately unplug the unit from the AC line and check cable wiring!
4. You may wish to repeat step 6 to confirm operation over a wide range of bearings. If the operation is consistent, proceed to the next step.
5. Calibrate the rotation stops of the DCU-2.
 - a. Rotate to the left manually by pressing the LEFT button till the rotator reaches the left mechanical stop then release.
 - b. Press and hold the MENU button till the menu is displayed.
 - c. Turn the "HEADING SET" knob if necessary to select

DCU-2 Digital Antenna Rotator Controller

- “1.CALIBRATE” then press the Heading set knob in to select the function.
- d. Turn the knob to select “1. LEFT STOP SOUTH” then press the Heading Set knob in to select. You may see the display change to between 179 and 181 and the display will say “LEFT STOP”.
 - e. Next rotate the rotator to the right mechanical stop using the RIGHT button.
 - f. Press and hold the MENU button till the menu is displayed.
 - g. Turn the Heading Set knob if necessary to select “1.CALIBRATE” then press the Heading set knob in to select the function.
 - h. Turn the knob to select “2. RIGHT STOP SOUTH” then press the “HEADING SET” knob in to select. You may see the display change to 179 or 180 and the display will say “RIGHT STOP”.
6. Rotate the system to the center of rotation. You are now ready to install the rotator system in your tower or on your mast. Follow the instructions that came with your rotator.

Rotator Installation Precautions

Installation of the rotator and antenna needs to be done with the upmost care because of the hazards that are associated with tower climbing and power line contact. There are also precautions that will allow for smoother operation and a longer lifetime of the equipment

1. Unbalanced weight: Weight should be as closely balanced as possible. Unbalanced weight in an antenna creates a bending moment of force which is concentrated on the mast at the point where it is clamped to the rotator.
2. Wind Pressure: Balanced wind pressure against the antenna system produces a bending force on the mast which can cause the same stresses as unbalanced weight. To minimize these forces, a thrust bearing should be used where possible; the antenna should be as close to the top of the tower as possible and the rotator shelf should be as low as possible.
3. Unbalanced Wind: If the antenna has unequal wind areas and element spacing on each side of the mast attachment point, it could produce torque on the support mast. This is similar to the principle of a weather vane. If the unbalance is high enough or the wind velocity is high enough, this could prevent rotation or could damage the limit switches. To minimize this effect, the antenna should be designed for minimum mast torque or "torque compensators" added to produce minimum mast torque.
4. Mast Binding: If the antenna support mast binds within the tower due to ice accumulation or other reasons, this could prevent rotation. The DCU-2 checks for rotator movement upon pressing "ROTATE", and if no movement is detected within 8 seconds, it will stop.
5. Extreme Cold: If the ambient temperature is at or below -30 degrees F, this could prevent rotation. If no movement is detected within 8 seconds of pressing "ROTATE", then the rotator will stop.

Section 5 Operation of DCU-2

Manual Operation

MANUAL ROTATION This mode is like the simpler controllers where pressing the LEFT or the RIGHT button will cause the rotator to move to the left or CCW or the right or CW. The brake will disengage and stay disengaged for the delay time after the release of the LEFT or RIGHT buttons.

HEADING SET This mode you can dial in the desired heading with the HEADING SET knob then pressing the ROTATE button. The antenna will rotate to the selected heading and then stop. The rotator will normally stop within about 2 to 5 degrees of the desired heading once the COAST SET is set correctly. Fine tuning of the heading can be made with the manual buttons if desired. Holding in the ROTATE button for more than 2 seconds will set the reverse heading.

Computer Operation

The DCU-2 may be controlled from your computer using third party control software via an RS-232 cable connection or a USB connection and can use either but not both at the same time. To select which one to use table the top cover off of the DCU-2 and on the back of the main board is a jumper on a 3 pin header. For RS-232 put the jumper between the center and the R side pin. For USB put the jumper between the center pin and the U side pin.

RS-232 Input

The rear panel has two (2) RS-232 connectors. The connector marked "INPUT" is a DB9 female connector and should be directly connected to the host computer. Do not use a null modem connection. The connector marked "OUTPUT" is a DB9 male connector and can be connected to

other ham equipment such as a modem, TNC, or radio interface unit. The cable which is attached to the computer and to the DCU-2 should have a DB9 male connector at one end and either a DB9 female or DB25 female connector at the other end. The connections should be straight through, e.g. pin 1 to pin 1, pin 2 to pin 2, etc if both ends have 9 pin connectors. If a DB25 female connector is used to attach to the computer's COM port, use the wiring guide shown in Figure 6. You may also purchase a pre-assembled cable from **hy-gain** to connect your computer to the DCU-2. Order either DCU-9P or DCU-25P cable assemblies.

USB Input

For USB communications plug a USB cable with the proper connector to the DCU-2 and then the other end into the computer USB port. First time installation may require installation of drivers for the USB IC. These can be found at the manufacturer's web site: <http://www.ftdichip.com/Drivers/VCP.htm>. Choose the operating system and download the drivers. Follow the instructions that are included on the web page: <http://www.ftdichip.com/Support/Documents/InstallGuides.htm> for your operating system. Once the drivers are installed and the hardware is installed and ready to use you can then control the DCU-2 with any of the software available that will control the DCU-1. Both the DCU-1 and DCU-2 use the same command set. The USB chip is powered from the USB port so the port used must be able to supply power.

DCU-2 Digital Antenna Rotator Controller

Signal Name	DB9 PIN	DB25 PIN
DCD Data Carrier Detect	1	8
RD Receive Data	2	3
TX Transmit Data	3	2
DTR Data Terminal Ready	4	20
GND Signal Gnd	5	7
DSR Data Set Ready	6	6
RTS Request To Send	7	4
CTS Clear To Send	8	5
RI Ring Indicator	9	22

Figure 6 RS-232 Wiring Guide

Software Control

Follow the instructions for the software package that you use to control the rotator for setup and operation. For example in “Ham Radio Deluxe” the “HDR Rotator” control module asks for the Controller Type and the COM Port number. Other software vendors also include the ability to directly control the DCU-2 from within a logging or rig control program. Use the DCU-1 (or DCU-2 if in the list) and look for the COM port that the DCU-2 is plugged into. For RS-232 you should have a list of COM 1-4 depending on what is installed in the

computer and you would choose the one that the DCU-2 is plugged into. For USB you should have the COM 1-4 list and then a higher number COM list of the devices plugged into the computer that act as virtual com ports. Choose the one that the DCU-2 is connected to. If you unplug the DCU-2 the USB com port should no longer be available. If you have chosen the correct COM port then when instructed by the software the rotator should respond to the commands. If not then try one of the other COM ports.

COMMAND SET

There are 2 commands the DCU-2 is looking for that are sent as ASCII characters.

Command:	Result:
AP1***;	Sets Target Bearing in DCU-2 (***) is a three digit number between 000 and 359)
AM1;	Starts Rotation to Target Bearing

Figure 7 Command Set

DCU-2 Digital Antenna Rotator Controller

The COM port should be used at 4800 baud with no parity, 8 data bits, 1 stop bit and ASCII mode. This is usually shown as "4800,N,8,1".

After a command is sent to the DCU-2, all other motor and brake operation is

automatic. There are no provisions at this time to send current bearing information back to the computer.

You may wish to check with our Customer Service Dept. from time to time in order to obtain the latest firmware upgrades.

Menu Items

1. CALIBRATE
 - a. 1. LEFT STOP SOUTH
 - b. 2. RIGHT STOP SOUTH
2. OFFSET
 - a. Encoder sets the offset from the original setup. Press the encoder to select the change
 - b. Default is 0. Range is plus or minus 10 degrees
3. CALLSIGN
 - a. Turn the encoder to display the character then press the encoder to select and advance to the next character. Press a second time to save the call sign.
4. DEFAULTS
 - a. Resets back to original settings. Select YES or NO to reset.
 - b. All memory settings are retained till it is set back to Default.
5. BRAKE DELAY
 - a. Default is 3 seconds
 - b. Turn the encoder for 0 to 8 seconds in 0.1 second steps.
6. NORTHSTOP
 - a. Default is NO
 - b. Use the encoder to select YES or NO then press the encoder.
7. SLEEP DELAY
 - a. Default is 10 minutes
 - b. Set 1 to 255 minutes or 0 for always on.
8. COAST SET
 - a. Default 0
 - b. Sets the heading that will turn of the motor before it reaches the heading so it will coast to that heading. 0 to 10 degrees. Use this in conjunction with the Brake Delay.
9. REVERSE LCD
 - a. Default is NORMAL where the characters are light and the background is blue/dark.
 - b. REVERSE is blue/dark characters and light background.

Menu Function Details

OFFSET is used to compensate for any mechanical errors that may be in the antenna heading. For example if the antenna when set to 360 degrees and it is found to be off actually pointing at 355 degrees the **OFFSET** can be set to compensate for this error.

BRAKE DELAY has a default of 3 seconds which for antennas that have a large mass. Adjust it up to allow the antenna to quit moving before the brake engages.

COAST SET is used to compensate for overshoot of the heading. The inertia of large mass antennas will cause them to pass the desired heading and setting this adjustment will help by turning off the motor and let the antenna coast to the desired spot. This will have to be tried experimentally to find the best setting for your antenna. This in conjunction with the Brake Delay will set the required time to insure the antenna has stopped before locking down the desired heading.

CALLSIGN is used to set up the call sign display on the screen if desired. Select the menu function then enter the characters by turning the Heading Set knob to the desired character then press the knob in to allow selection of the next character. Once all the characters have been entered press the knob again to exit the mode.

NORTHSTOP In some cases you may want your antenna centered toward the south with the stops at the north. If this is the case put up the antenna centered to the south and once installed and ready select this function and turn the Heading Set knob to select YES then press the knob in.

SLEEP DELAY is used to put the control into a sleep mode where the LCD back light turns off and the microprocessor goes into a low power state. It will wake back up with the press of any button or any command on the COM port. Selecting this menu will allow you to set the time from 0 to 240 in minutes. 0 is always on. When the unit goes to sleep the back light will turn off and it will not accept manual rotor commands till any button is pushed. It will wake up with a computer command. It will not wake up with a turn of the rotary encoder.

REVERSE LCD changes the characters and background from dark blue background and white letters to a white background and dark letters as viewed from straight on. When viewed from a side angle or above the display at the display viewing limits, the characters in normal mode may look dark with a light background. To select the reverse mode select this menu item then turn the Heading Set knob to say YES for reverse or NO for normal then press the knob to select.

Section 6 Troubleshooting

CAUTION:

This unit has been thoroughly tested and cycled before shipment. Follow the connector wiring carefully between the rotator and the DCU-2 control box. Pin #1 must attach to Pin #1, etc. Incorrect wiring

Wiring

Most operational difficulties with rotators are traceable to broken, shorted, grounded or miswired control cables. Time spent on assembling, routing and protecting the control cable will lead to a long trouble free rotator life.

Unintentional grounds on cable leads can burn out the line fuse in the DCU-2 control

Antenna Motion

Frequently the slight motion of the antenna array in gusts of wind is due more to the natural flexing of the elements and mast than to actual play in the rotator mechanism. A slight amount of “play” is built into the rotator to avoid binding due to environmental changes.

If the antenna actually rotates in high winds, this is usually just the mast slipping in the rotator or the antenna slipping on the mast.

Lack of Power

If the antenna rotation is slow or sluggish or hard to start, check for proper voltages on pins #2,5, and 6. (See Table 5) If the voltages are correct, the 130-156 MFD capacitor may be old. If your unit is more than 5 years old, try replacing this capacitor. Also, if your cable run is over 200 feet, make sure that you are using the proper wire size. See Table 2. For cable runs over 300 feet, you may wish to move the motor capacitor to the tower. This allows you to run only 6 wires from the control to the rotator, so that you can reduce wire

will burn out the rotator potentiometer and void the warranty.

The DCU-2 control unit is designed to be used ONLY with **hy-gain** HAM-IV (type) and T2X rotator systems. Do not try to use this control on other systems.

box or burn out the potentiometer in the rotator. If pin #3 is grounded, the heading will be wrong and possibly not rotate in the proper direction. Note also that any grounds may put an overload on the power transformer which could cause the line fuse to blow.

For large antennas, it is often necessary to drill a 5/16” hole through the rotator clamping plate and mast and pin them together with the bolt provided. Also, if possible, pin the antenna to the mast with appropriate hardware. If slipping is suspected, return the rotator to an end of rotation limit and visually check antenna alignment.

resistance by doubling up wires or using fewer, heavier wires.

If the electrical circuit is working, then check for mechanical problems. Look for mast binding or thrust bearing misalignment if you have experienced strong winds recently. If the temperature is less than -30 deg. F (-34 deg. C), the rotator will be very sluggish or may not run at all! This is normal. Do not try to rotate with the DCU-2 control if temperatures are below -30 deg. F!

DCU-2 Digital Antenna Rotator Controller

Table 4 Troubleshooting Chart

Problem	Possible Cause
Antenna Bearing doesn't match display	Mast slipped in rotator clamp
	Antenna slipped on mast
	DCU-2 Calibration not performed
Current Bearing changes randomly or does not change at all	Potentiometer broken or burned up
	Shorts or opens in control cable
	Extremely high RF field near rotator
	DCU-2 MPU or A/D failure
	Tower or DCU-2 not grounded
Antenna Bearing changes by itself	Brake wedge failure
	DCU-2 MPU failure
Current Bearing changes +/- less than 3 degrees	Antenna rocking in high winds
	Potentiometer dirty or poor connection
	High RF field near rotator
	Long (200') control cable
Rotator unable to reach target bearing	Temperature less than -30 degrees F
	Broken teeth in gears
	Shorts or opens in control cable
	Thermal cutout in power transformer
	Mast binding in tower
	Old motor-start capacitor
	High winds, high wind area
	Control cable wire size too small
DCU-2 MPU failure	
Rotator slow to reach target bearing	Temperature between -30 and 0 degrees F
	Broken teeth in gears
	Mast binding in tower
	Old motor-start capacitor
	High winds
BROWNOUT DETECTED error message when turning the DCU-2 on.	The MPU in the DCU-2 detects when the voltage is below 4.3 volts. This will happen occasionally but if it happens every time there may be a problem on the PCB with the voltage regulator.
EPROM SET BACK TO DEFAULT error message	Normal if unit was reset back to default or the firmware was updated.
	PCB Problem.
Displays 999 and/or CABLE	Cable unplugged
	Potentiometer in rotor bad
	Cable broken
Displays MOTOR	No rotator movement detected in 8 seconds of command to rotate.

DCU-2 Digital Antenna Rotator Controller

Checking the Control Unit Voltages

To check the control unit voltages, first remove the rotator control cable from the DCU-2 control box, then plug the line cord into a 120 VAC outlet. Set the target bearing

at least 10 degrees from the current bearing. Press "ROTATE" to check the voltages on pins 2, 5, and 6. Check for the following voltages on the 8 pin connector:

Pin #'s	Ambient State	Press "ROTATE" (see note)
1-2	0	30 VAC
1-5	0	30 VAC (for CW rotation to target)
1-6	0	30 VAC (for CCW rotation to target)
4-8	0	0
3-1	+ 8.0 VDC	+ 8.0 VDC
3-1	0 to 4.0VDC	<i>With Rotator Cable Connected</i>

Table 5 Voltage Readings

NOTE:

You have 8 seconds after pressing "ROTATE" to make each measurement. The DCU-2 checks for movement, and after 8 seconds without movement, it stops trying

to rotate. You may wish to make your meter connections with alligator clips, then press "ROTATE" when you are ready to read the meter.

Checking the Rotator Resistances

You may possibly avoid bringing the rotator down from the tower by making electrical resistance checks on the control

cable. Disconnect the control cable from the control box. Check for the following resistances.

Description	Pin #'s	Approximate Resistance (ohms)
Brake Solenoid	1-2	0.75 + cable resistance
1/2 Motor Winding	1-8	2.5 +cable resistance
1/2 Motor Winding	1-4	2.5 +cable resistance
1/2 Motor Winding + switch	1-6	2.5 +cable resistance
Entire Motor	4-8	4.5 + cable resistance
Right Limit Switch	5-8	0 +cable resistance
Left Limit Switch	4-6	0 + cable resistance
Entire Pot	3-7	500 (±50) + cable resistance
Pot Arm to + End	1-3	0 to 500 (0 at full CCW)
Pot Arm to - End	1-7	0 to 500 (500 at full CCW)

Table 6 Rotator Resistance Chart

Heading Notes

Reading and control near the stops may not always go to the exact location instructed. Near the right stop the voltage is very low and noise and AC hum interfere with the readings. This is due to the way the rotators are wired with the

position pot center wiper at ground. Headings between 180 and 200 degrees may be difficult to reach with automatic control. A similar issue is found between 180 right stop and 160 degrees when rotating off of the right stop.

Section 7 DCU-2 Control Unit Block Diagram

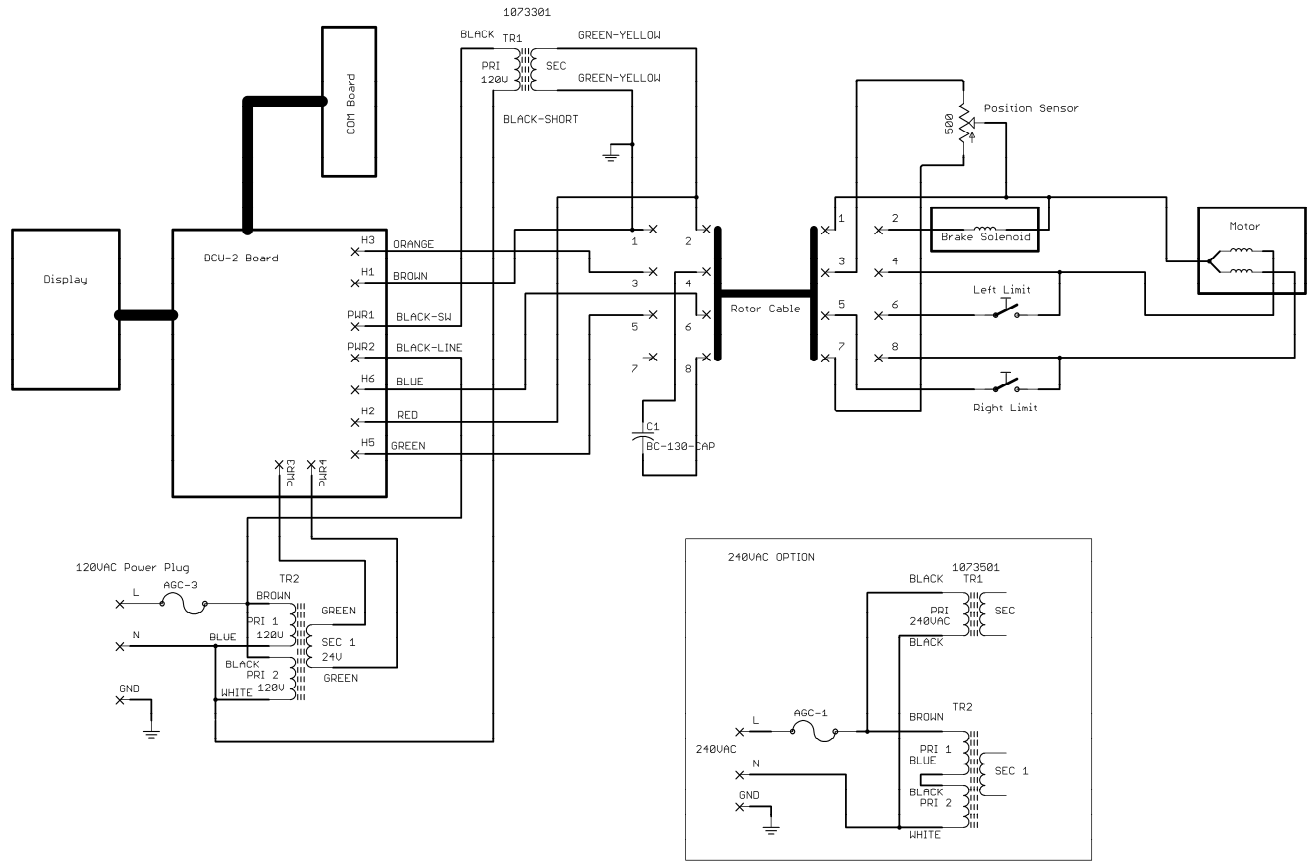

Figure 8 DCU-2 Block Diagram

Table 7 DCU-2 Chassis Parts

Part Num	Value	Quantity
500160	10-24X5/8 SS Screw	1
520057	6-32X3/8 Black type F	8
551153	10-24 wing nut SS	1
554071	10-24 SS NUT	1
556990	8-32 SS NUT	4
640076	8 pin Female Jones Connector	1
667621	#10 ring lug crimp on	3
671673	Spade lug crimp on	2
1073301	MAIN transformer 120V (for 120VAC units only)	1
1073501	MAIN transformer 240V (optional for 240VAC units only)	1
5017702	Meter Transformer	1
5104700	#8 EXT TOOTH Lock Washer	4
270-6220-1	220uF 25V capacitor	1
610-5020	Power Connector	1

DCU-2 Digital Antenna Rotator Controller

Part Num	Value	Quantity
654-0187	4-40X3/16 screw	8
654-0250	4-40X1/4 screw	4
654-0500-CP	4-40X1/2 SS Flat Head Screw	2
654-0500S	4-40X1/2 SS screw	4
656-0250S	6-32X1/4 SS screws	7
705-0440S-K	4-40 KEP NUT	9
705-0632S-K	6-32 KEP Nut	7
711-1037-EX	#10 EXT TOOTH Lock Washer	2
716B-0250	4-40 X 1/4 hex threaded spacers	4
716B-0250	4-40X1/4 hex threaded spacers	4
716B-0500	4-40 X 1/2 hex threaded spacers	4
5151501	130 uF Motor Run Capacitor	1
745-2149	white tie wraps	2
745-2158B	black tie wraps	2
755-2148	Fuse Holder	1
760-0033	Knob	1
5091400	Grommet	2
782-DCU2	Front Panel Decal	1
800-DCU2	Chassis	1
802-DCU2	Front Panel	1
803-DCU2	Back Panel	1
620-6130	Power Cord (120VAC)	1
620-6134	Power Cord (optional 240VAC HAM-VIX)	1
755-0103	3A 250V Fast Blow AGC-3 (120VAC)	1
755-0101	1A 250V Fast Blow AGC-1 (optional 240VAC HAM-VIX)	1
5141100	Top Cover	1
5141200	Bottom Cover	1

Section 8 DCU-2 Printed Circuit Board

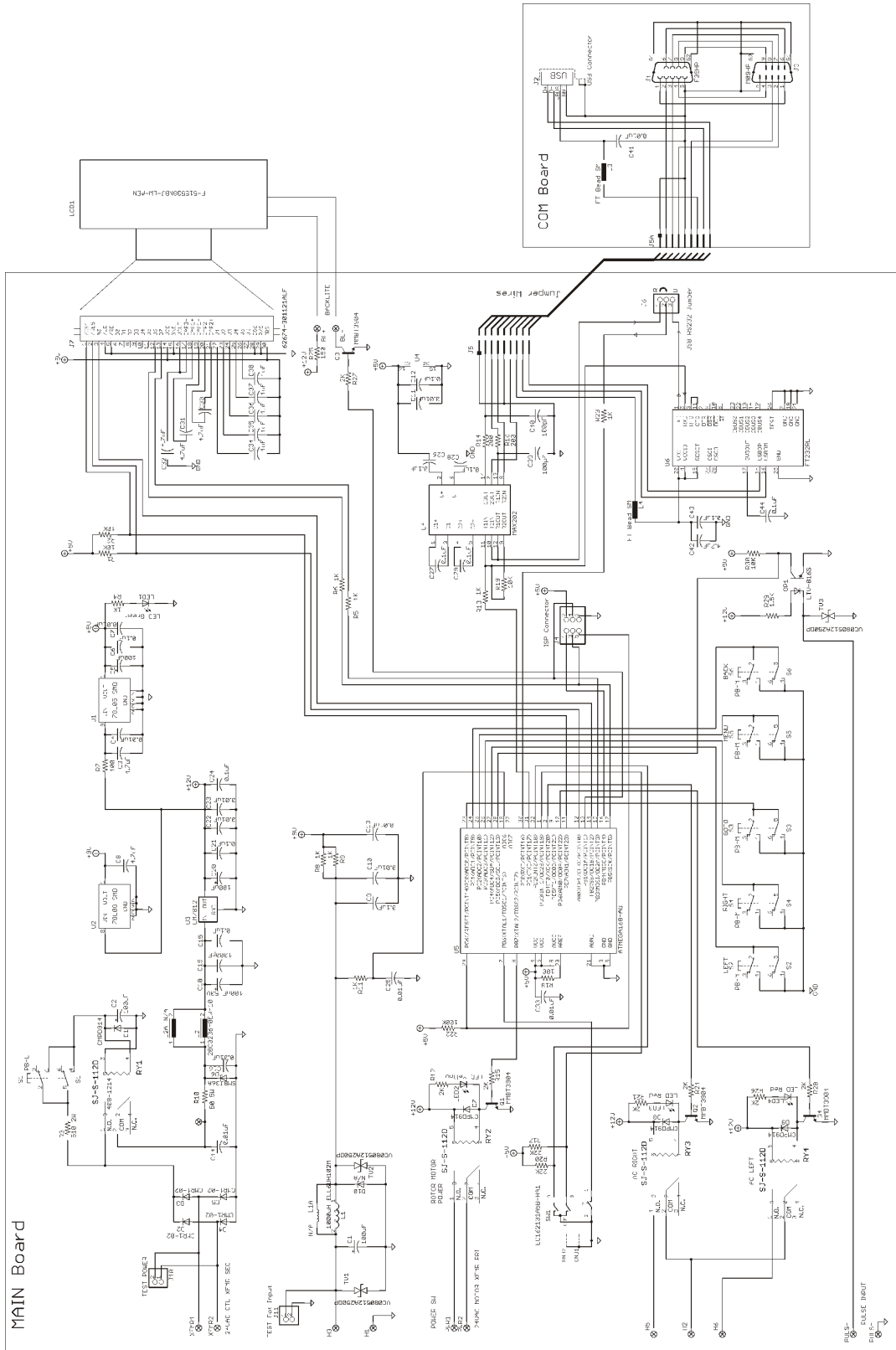

Figure 9 DCU-2 PCB Schematic Diagram

DCU-2 Digital Antenna Rotator Controller

Table 8 DCU-2 PC Board Parts

Part Num	Value	Parts	Qty
270S-6100	100uF	C1, C2, C5, C20	4
270S-6100-2	100uF 50V	C18	1
200S-2100	1000pF	C19	1
200S-4470-1	4.7uF	C3, C8, C30, C31, C32, C42	6
200S-4100	1uF	C34, C35, C36, C37, C38	5
200S-0100	100pF	C39, C40	2
200S-2100	0.01uF	C4, C7, C10, C13, C14, C16, C22, C23, C25, C33, C41	11
200S-3100	0.1uF	C6, C9, C11, C12, C15, C21, C24, C26, C27, C28, C29, C43, C44	13
Part Num	Value	Parts	Qty
300S-0914	CMPD914	D1, D7, D8, D9	4
300S-4001	CMR1-02	D2, D3, D4, D5	4
301S-0036	SMBJ36A	D6	1
612S-5030	62674-301121ALF	J7	1
401S-6100-2	1000uH ELL6UH102M	L1	1
412S-3226	FT Bead SM	L3, L4	2
356-0816-SM	LTV-816S	OP1	1
305-3904-SM	MMBT3904	Q1, Q2, Q3, Q4	4
100S-4100	10K	R1, R2, R19, R30	4
100S-3200	2K	R12, R15, R21, R24, R26, R27, R28	7
100S-2200	200	R14, R16	2
100S-4100	22K	R17, R20	2
100S-5100	100K	R22	1
100S-2150	150	R25	1
100S-3150	1.5K	R29	1
100S-3100	1K	R4, R5, R6, R8, R9, R11, R13, R23	8
100S-2100	100	R7, R18	2
304S-12250	VC080512A250DP	TV1, TV2, TV3	3
307S-78L05	78L05 SMD	U1	1
307S-78L08	78L08 SMD	U2	1
325-0202-SM	MAX202	U4	1
328-0168-SM	ATMEGA168-AU	U5	1
325-0232RL-SM	FT232RL	U6	1
105-1510W	50 5W	R10	1
104-2560	560 2W	R3	1
408-1214	SJ-S-112D	RY1, RY2, RY3, RY4	4
610-3009	F09HP	J1	1
601-8201	USB Connector	J2	1

DCU-2 Digital Antenna Rotator Controller

Part Num	Value	Parts	Qty
610-3109	M09HP	J3	1
412-6131-PW	28C0236-0EW-10	L2	1
354-51320	F-51553GNBJ-LW-AEN	LCD1	1
351-5002	LED Green	LED1	1
351-5005	LED Yellow	LED2	1
351-5004	LED Red	LED3, LED4	2
504-2022	PB-L	S1	1
504-4022M	PB-M	S2, S3, S4, S5, S6	5
580-0028	EC162101A5B-HA1	SW1	1
307-7812	LM7812	U3	1
750-0232	TO220 Heat sink		1
760-2059	White Push Button Cap		5
760-2052	Red Push Button Cap		1
654-0250	4-40X1/4 screw		1
705-0440	4-40 nut		1
612-4001	Shorting Jumper		1
862-DCU2	PC BOARD		1
718-1425-0250	0.250 nylon spacer		4
718-1425-0125	0.125 nylon spacer		4

Table 9 Connector Parts Pack PN 870598

Item Number	Part Number	Description	Qty
176	650181	Plug, Amp	1
177	650180	Shell, Amp	1
178	650082	Contact, Socket	8
179	640077	Plug, 8 Pin	1

Table 10 DCU-2 120V Parts Pack

Part Number	Description	Qty
755-0103	Fuse 3A Fast Blow AGC-3	2

Table 11 DCU-2 240V parts Pack

Part Number	Description	Qty
755-0101	Fuse 1A Fast Blow AGC-1	2

DCU-2 Digital Antenna Rotator Controller

Notes:

How to Get Factory Service

If service is required, the unit must be packed and sent prepaid to:

hy-gain[®]

**308 Industrial Park Rd.
Starkville, MS 39759 USA**

Ph: (662) 323-9538 FAX: (662) 323-6551

For units that are in warranty, no charges will be made for any repair work required.

For out-of-warranty units, call the Warranty Service Department for prices

The price includes rebuilding the unit, replacing all defective and/or worn parts, and return freight charges.

hy-gain reserves the right to change prices at its option.

When returning items for repair, a check or money order for the repair charges must be included.

Be sure to include your name, address, zip code, and telephone number. Also, give a brief description of the problem.

DCU2 Digital Antenna
Rotator Controller
For the
HAM-IV and T-2X

Model DCU-2 Instruction Manual

Firmware 1B

hy-gain[®]

308 Industrial Park Road
Starkville, MS 39759 USA

Table of Contents

DCU-2 Digital Antenna Rotator Controller	3
DCU-2 Digital Control Unit Specifications:	3
Precautions.....	4
Installation	5
Rotator Precautions	5
Wiring and Check-Out.....	5
Operation of DCU-2 Controller	9
Menu Functions.....	9
OFFSET	9
BRAKE DELAY	9
COAST SET.....	10
CALLSIGN	10
NORTHSTOP	10
SLEEP DELAY	10
REVERSE LCD	10
CONTRAST.....	10
Manual Operation.....	10
MANUAL ROTATION.....	10
HEADING SET.....	10
Computer Operation	11
RS-232	11
USB	11
Software Control.....	12
COMMAND SET.....	12
Troubleshooting	13
Wiring.....	13
Antenna Motion.....	13
Lack of Power	13
Checking the Control Unit Voltages.....	15
Checking the Rotator Resistances.....	15
Heading Notes	16
How to Get Factory Service.....	21
Figure 1 Front Panel	3
Figure 2 Back Panel.....	3
Figure 3 Control Cable Connector Attachment.....	6
Figure 4 LCD Display	7
Figure 5 RS-232 Wiring Guide	11
Figure 6 Command Set.....	12
Figure 7 DCU-2 Block Diagram	17
Figure 8 DCU-2 Main PCB Schematic.....	17
Table 1 Wire Color List	5
Table 2 Wire Size	6
Table 3 Recommended Cables	6
Table 4 Troubel shooting Suggestions	14
Table 5 Voltage Readings	15
Table 6 Rotator Resistance Readings	15
Table 7 Chassis Parts	18
Table 8 Printed Circuit Board Parts	19

DCU-2 Digital Antenna Rotator Controller

The DCU-2 digital control unit features a Large LCD display indicating the beam heading, manual and computer controlled beam heading selection, manual rotation controls. Settings in memory include break delay, rotator coast control, North and South center headings, adjustable sleep time, and call sign display.

Your existing rotator unit (HAM IV, T2X, or compatible) must be connected to the control unit with an 8-wire cable. You may use your existing cable, you may assemble your own cable from the information supplied in this manual, or you may purchase pre-assembled.

DCU-2 Digital Control Unit Specifications:

Size 4.125" x 8.5" x 9"
 Weight 6.25 lbs. (2.84 Kg)
 Voltage 120VAC or 240VAC (optional HAM VIX)

Brake Delay 0-8 seconds DEFAULT 3
 Coast Delay 0-10 seconds DEFAULT 0
 Sleep Delay 1-240 minutes or continuous ON DEFAULT 20

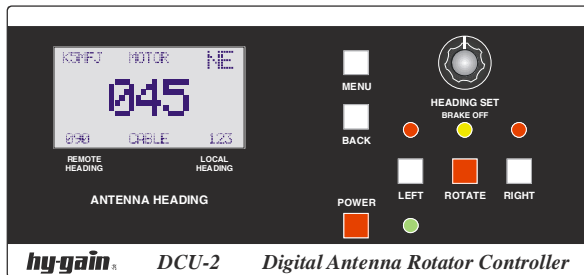

Figure 1 Front Panel

Front Panel Controls

POWER Power ON/OFF
LEFT Manually rotate left/CCW
RIGHT Manually rotate right/CW
HEADING SET Set the locally controlled antenna heading or bearing. Pushing in the "HEADING SET" selects any menu function selected or executes the menu function.
ROTATE Instructs the controller to rotate the antenna to the locally set heading.
MENU Displays the menu on the LCD screen.
BACK Backs out of any menu instruction without executing the instruction.

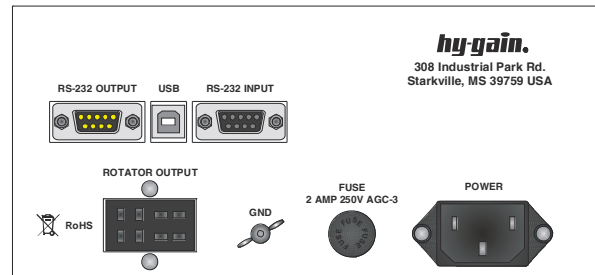

Figure 2 Back Panel

Back Panel Connections

RS-232 INPUT Input COM Port
GROUND Chassis ground
RS-232 OUTPUT Output loop through
FUSE Protective fuse
USB USB COM Port
ROTATOR OUT Rotator connections
POWER 120 VAC Input
 (240VAC Input optional)

Precautions

Towers and antennas require caution during erection and placement! Extreme care must be taken during erection so that metal tower and antenna parts DO NOT contact power lines, even if the parts slip, rotate, retract, fall or fracture!

Antenna position mechanisms (towers and rotators) must be placed so that if they fail, the parts of the antenna system cannot contact power lines, be a hazard to individuals, or endanger property.

Metal towers must be grounded properly at the tower location before the tower is erected. This is to minimize electrical hazard and the possibility of lightning damage. DO NOT bury bare aluminum wires or stakes in the ground. Use copper or copper-clad ground stakes. The service entrance ground should be checked. The household electrical outlet should be the 3-prong type (grounded back to the service entrance).

It is recommended that you use a "daisy-chain" ground connection rather than connecting all units (DCU-2, radio, tuner, etc.) to the ground rod separately.

The DCU-2 Control Unit is not weatherproof and must be located in a house or other protected location. Connect a ground wire to the 1/4"-20 terminal on the back of the DCU-2.

The DCU-2 has been carefully designed and manufactured to give many years of trouble-free service when carefully and professionally installed. It consists of the strongest and best commercially available components. This product is manufactured in the U.S.A.

Installation

Rotator Precautions

1. Unbalanced weight: Weight should be as closely balanced as possible. Unbalanced weight in an antenna creates a bending moment of force which is concentrated on the mast at the point where it is clamped to the rotator.
2. Wind Pressure: Balanced wind pressure against the antenna system produces a bending force on the mast which can cause the same stresses as unbalanced weight. To minimize these forces, a thrust bearing should be used where possible, the antenna should be as close to the top of the tower as possible and the rotator shelf should be as low as possible
3. Unbalanced Wind: If the antenna has unequal wind areas and element spacing on each side of the mast attachment point, it could produce torque on the support mast. This is similar to the principle of a weather vane. If the unbalance is high enough or the wind

velocity is high enough, this could prevent rotation or could damage the limit switches. To minimize this effect, the antenna should be designed for minimum mast torque or "torque compensators" added to produce minimum mast torque.

4. Mast Binding: If the antenna support mast binds within the tower due to ice accumulation or other reasons, this could prevent rotation
5. Extreme Cold: If the ambient temperature is at or below -30 degrees F, this could prevent rotation. Older HAM-M, II, III or IV and older T2X units may be sluggish at temperatures less than 0 degrees F.

The DCU-2 checks for rotator movement upon giving the command to rotate and if no movement is detected within 8 seconds, it will stop trying to rotate. If no movement is detected the display will flash MOTOR above the main heading display.

Wiring and Check-Out

1. Write down the colors of the wires attached to your existing rotator control unit:

CAUTION:

The new connector is numbered differently than the terminal strip. Pay close attention to the pin numbers! You may wish to check your wiring by measuring the rotator resistances as shown in Table 6 Rotator Resistance Readings.

Terminal	Color
1	
2	
3	
4	
5	
6	
7	
8	

Table 1 Wire Color List

2. Disconnect the wires from your existing control unit. Attach these to the 8-pin connector to the same numbered pins.
3. If this is a new installation, assemble the rotator cable as shown in Figure 3, or purchase a pre-assembled cable.
4. Temporarily attach the mounting screws to the bottom of the rotator unit. These will be used to support the rotator during bench-testing.

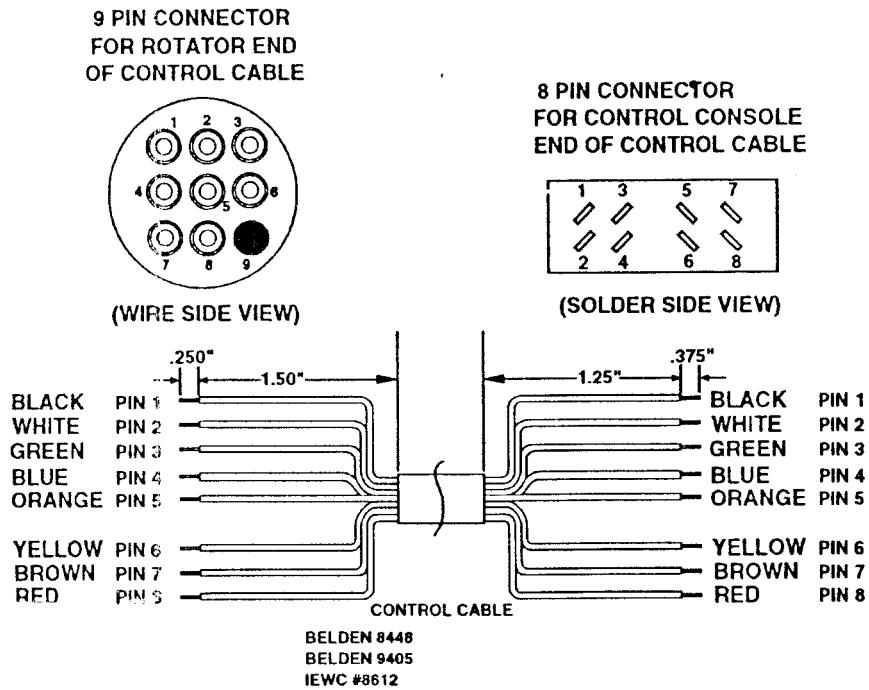

Figure 3 Control Cable Connector Attachment

CAUTION:

Shorts between terminals or grounded leads may damage the rotator. Check the numbered pins on each connector with an Ohmmeter! Pin 1 is connected to pin 1, etc.

NOTE:

The specifications call for heavier gauge wire in two locations. Leads #1 and #2 must be heavier gauge and less total lead resistance

Maximum Length	Gauge for Terminals 1 & 2	Gauge for Terminals 3-8
125' (38 M)	#18 (1.19 mm)	#20 (0.97 mm)
200' (61 M)	#16 (1.42 mm)	#18 (1.19 mm)
300' (91 M)	#14 (1.75 mm)	#16 (1.42 mm)

Table 3 Wire Size

Belden 8448
 Belden 9405
 IEWC #8612
Table 2 Recommended Cables

5. With the rotator sitting in the upright position (either on the bench or on the tower) and connected to the control unit by the 8-wire cable, plug the control unit power cord into a receptacle.
6. The DCU-2 display should look similar to the display shown in Figure 4. The numeric display in the center indicates the current bearing of your rotator. The numeric display in the lower right corner indicates the target bearing that is manually set. The numeric display in the lower left indicates target bearing that is computer set. The character display in the upper right corner indicates the compass heading in "NESW" format. The alphanumeric display in the upper left corner is where the call sign is displayed if programmed. If the center display reads a steady "999", disconnect your control cable and check the cable wiring with an ohmmeter. See the section "Checking the Rotator Resistances from the Ground". Proceed if the cable checks OK. 999 also indicates that the cable may not be plugged in.



Figure 4 LCD Display

MOTOR is displayed when there is no indication of rotator movement and CABLE also indicates a cable problem.

7. If the current bearing display shows a number between "000" and "359", then proceed. Twist the HEADING SET

knob. LOCAL HEADING display should. Using the knob, select a target bearing at least 30 degrees from the current bearing. Push the "ROTATE" button. The brake in the rotator should release, the rotator will turn a few degrees in the opposite direction, reverse direction, and then turn to the target bearing. The rotator should turn to the heading plus or minus 2 or 3 degrees. The brake solenoid will "hum" for 3 seconds or what the menu brake setting was set to if changed, then the brake will engage. During rotation the display will show the actual heading as it turns. If operation does not work as described, immediately unplug the unit from the AC line and check cable wiring!

8. You may wish to repeat step 6 to confirm operation over a wide range of bearings. If the operation is consistent, proceed to the next step.
9. Calibrate the rotation stops of the DCU-2.
 - a. Rotate to the left manually by pressing the LEFT button till the rotator reaches the left mechanical stop then release.
 - b. Press and hold the MENU button till the menu is displayed.
 - c. Turn the Heading Set knob if necessary to select "1.CALIBRATE" then press the Heading set knob in to select the function.
 - d. Turn the knob to select "1. LEFT STOP SOUTH" then press the Heading Set knob in to select. You may see the display change to 179 or 180 and the display will say LEFT STOP.

- e. Next rotate the rotator to the right mechanical stop using the RIGHT button.
- f. Press and hold the MENU button till the menu is displayed.
- g. Turn the Heading Set knob if necessary to select "1.CALIBRATE" then press the Heading set knob in to select the function.
- h. Turn the knob to select "2. RIGHT STOP SOUTH" then press the Heading Set knob in to select.

You may see the display change to 179 or 180 and the display will say RIGHT STOP.

- 10. If this is a new installation, rotate the system to the center of rotation. You are now ready to install the rotator system in your tower or on your mast. Refer to the instructions in your rotator manual for complete installation information.

Operation of DCU-2 Controller

Menu Items

1. CALIBRATE
 - a. 1. LEFT STOP SOUTH
 - b. 2. RIGHT STOP SOUTH
2. OFFSET
 - a. Encoder sets the offset from the original setup. Press the encoder to select the change
 - b. Plus or minus 10 degrees
3. CALLSIGN
 - a. Turn the encoder to display the character then press the encoder to select and advance to the next character. Press a second time to save the call sign.
4. DEFAULTS
 - a. Resets back to original settings. Select YES or NO to reset.
 - b. All memory settings are retained till it is set back to Default.
5. BRAKE DELAY
 - a. Default is 3 seconds
 - b. Turn the encoder for 0 to 8 seconds in 0.1 second steps.
 - c. May need to have longer delay than 8 seconds
6. NORTHSTOP
 - a. Default is NO
 - b. Use the encoder to select YES or NO then press the encoder.
7. SLEEP DELAY
 - a. Default is 10 minutes
 - b. Set 1 to 255 minutes or 0 for always on.
8. COAST SET
 - a. Default 0
 - b. Sets the heading that will turn of the motor before it reaches the heading so it will coast to that heading. 0 to 10 degrees. Use this in conjunction with the Brake Delay.
9. REVERSE LCD
 - a. Default is NORMAL where the characters are light and the background is blue/dark.
 - b. REVERSE is blue/dark characters and light background.
10. CONTRAST
 - a. Set for best contrast. Range is 1 to 32 with a setting around 20 to 25 for normal contrast. (added 3-5-14)

Menu Functions

OFFSET is used to compensate for any mechanical errors that may be in the antenna heading. For example if the antenna when set to 360 degrees and it is found to be off actually pointing at 355 degrees the

OFFSET can be set to compensate for this error.

BRAKE DELAY has a default of 3 seconds which for antennas that have a large mass.

Adjust it up to allow the antenna to quit moving before the brake engages.

COAST SET is used to compensate for overshoot of the heading. The inertia of large mass antennas will cause them to pass the desired heading and setting this adjustment will help by turning off the motor and let the antenna coast to the desired spot. This will have to be tried experimentally to find the best setting for your antenna. This in conjunction with the Brake Delay will set the required time to insure the antenna has stopped before locking down the desired heading.

CALLSIGN is used to set up the call sign display on the screen if desired. Select the menu function then enter the characters by turning the Heading Set knob to the desired character then press the knob in to allow selection of the next character. Once all the characters have been entered press the knob again to exit the mode.

NORTHSTOP In some cases you may want your antenna centered toward the south with the stops at the north. If this is the case put up the antenna centered to the south and once installed and ready select this function and turn the Heading Set knob to select YES then press the knob in.

Manual Operation

MANUAL ROTATION This mode is like the simpler controllers where pressing the LEFT or the RIGHT button will cause the rotator to move to the left or CCW or the right or CW. The brake will disengage and stay disengaged for the delay time after the release of the LEFT or RIGHT buttons.

HEADING SET This mode you can dial in the desired heading with the HEADING SET knob then pressing the ROTATE

SLEEP DELAY is used to put the control into a sleep mode where the LCD back light turns off and the microprocessor goes into a low power state. It will wake back up with the press of any button or any command on the COM port. Selecting this menu will allow you to set the time from 0 to 240 in minutes. 0 is always on. When the unit goes to sleep the back light will turn off and it will not accept manual rotor commands till any button is pushed. It will wake up with a computer command. It will not wake up with a turn of the rotary encoder.

REVERSE LCD changes the characters and background from dark blue background and white letters to a white background and dark letters as viewed from straight on. When viewed from a side angle or above the display at the display viewing limits, the characters in normal mode may look dark with a light background. To select the reverse mode select this menu item then turn the Heading Set knob to say YES for reverse or NO for normal then press the knob to select.

CONTRAST adjusts the contrast for best viewing. To adjust select this menu item and turn the heading control for best contrast. The range is 1 to 32 with a setting around 20 as best depending on the display batch received.

button. The antenna will rotate to the selected heading and then stop. The rotator will normally stop within about 2 degrees of the desired heading once the COAST SET is set correctly. Fine tuning of the heading can be made with the manual buttons if desired. Holding in the ROTATE button for more than 2 seconds will set the reverse heading.

Computer Operation

The DCU-2 may be controlled from your computer via an RS-232 cable connection or a USB connection and can use either but not both at the same time. To select which one to use take the top cover off of the DCU-2 and on the back of the main board is a jumper on a 3 pin header. For RS-232 put the jumper between the center and the R side pin. For USB put the jumper between the center pin and the U side pin.

RS-232

The rear panel has two (2) RS-232 connectors. The connector marked "INPUT" is a DB9 female connector and should be directly connected to the host computer. Do not use a null-modem connection. The

connector marked "OUTPUT" is a DB9 male connector and can be connected to other ham equipment such as a modem, TNC, or radio interface unit. The cable which is attached to the computer and to the DCU-2 should have a DB9 male connector at one end and either a DB9 female or DB25 female connector at the other end. The connections should be straight through, e.g. pin 1 to pin 1, pin 2 to pin 2, etc if both ends have 9 pin connectors. If a DB25 female connector is used to attach to the computer's COM1 or COM2 port, use the wiring guide shown in Figure 5. You may also purchase a pre - assembled cable from Hy-Gain to connect your computer to the DCU-2. Order either DCU-9P or DCU-25P cable assemblies.

Signal Name	DB9 PIN	DB25 PIN
DCD Data Carrier Detect	1	8
RD Receive Data	2	3
TX Transmit Data	3	2
DTR Data Terminal Ready	4	20
GND Signal Gnd	5	7
DSR Data Set Ready	6	6
RTS Request To Send	7	4
CTS Clear To Send	8	5
RI Ring Indicator	9	22

Figure 5 RS-232 Wiring Guide

USB

For USB communications plug a USB cable with the proper connector to the DCU-2 and then the other end into the computer USB port. First time installation may require installation of drivers for the USB IC. These can be found at the manufacturer's web site: <http://www.ftdichip.com/Drivers/VCP.htm>.

Choose the operating system and download the drivers. Follow the instructions that are included on the web page: <http://www.ftdichip.com/Support/Documents/InstallGuides.htm> for your operating system. Once the drivers are installed and the hardware is installed and ready to use you can then control the DCU-2 with any of

the software available that will control the DCU-1. Both the DCU-1 and DCU-2 use the same command set. The USB chip is

powered from the USB port so the port used must be able to supply power.

Software Control

Follow the instructions for the software package that you use to control the rotator for setup and operation. For example in Ham Radio Deluxe the Rotator control module asks for the Controller Type and the COM Port number. Other software vendors may also include the ability to directly control the DCU-2 from within a logging or rig control program. Use the DCU-1 (or DCU-2 if in the list) and look for the COM port that the DCU-2 is plugged into. For RS-232 you should have a list of COM 1-4 depending on what is installed in the computer and you

would choose the one that the DCU-2 is plugged into. For USB you should have the COM 1-4 list and then a higher number COM list of the devices plugged into the computer that act as virtual com ports. Choose the one that the DCU-2 is connected to. If you unplug the DCU-2 the USB com port should no longer be available. If you have chosen the correct com port then when instructed by the software the rotator should respond to the commands. If not then try one of the other com ports.

COMMAND SET

There are 2 commands the DCU-2 is looking for that are sent as ASCII characters.

Command:	Result:
AP1***;	Sets Target Bearing in DCU-2 (***)is a three digit number between 000 and 359)
AM1;	Starts Rotation to Target Bearing

Figure 6 Command Set

The COM port should be used at 4800 baud with no parity, 8 data bits, 1 stop bit and ASCII mode. This is usually shown as "4800,N,8,1".

After a command is sent to the DCU-2, all other motor and brake operation is

automatic. There are no provisions at this time to send current bearing information back to the computer.

You may wish to check with our Customer Service Dept. from time to time in order to obtain the latest firmware upgrades.

Troubleshooting

CAUTION:

This unit has been thoroughly tested and cycled before shipment. Follow the connector wiring carefully between the rotator and the DCU-2 control box. Pin #1 must attach to Pin #1, etc... Incorrect wiring

will burn out the rotator potentiometer and void the warranty.

The DCU-2 control unit is designed to be used ONLY with Hy-Gain HAM-IV (type) and T2X rotator systems. Do not try to use this control on other systems.

Wiring

Most operational difficulties with rotators are traceable to broken, shorted, grounded or miswired control cables. Time spent on assembling, routing and protecting the control cable will lead to a long trouble-free rotator life.

Unintentional grounds on cable leads can burn out the line fuse in the DCU-2 control

box or burn out the potentiometer in the rotator. If pin #3 is grounded, the heading will be wrong and possibly not rotate in the proper direction. Note also that any grounds may put an overload on the power transformer which could cause the line fuse to blow.

Antenna Motion

Frequently the slight motion of the antenna array in gusts of wind is due more to the natural flexing of the elements and mast than to actual play in the rotator mechanism. A slight amount of "play" is built into the rotator to avoid binding due to environmental changes.

If the antenna actually rotates in high winds, this is usually just the mast slipping in the rotator or the antenna slipping on the mast.

For large antennas, it is often necessary to drill a 5/16" hole through the rotator clamping plate and mast and pin them together with the bolt provided. Also, if possible, pin the antenna to the mast with appropriate hardware. If slipping is suspected, return the rotator to an end of rotation limit and visually check antenna alignment.

Lack of Power

If the antenna rotation is slow or sluggish or hard to start, check for proper voltages on pins #2,5, and 6. (See Table 4) If the voltages are correct, the 130 - 156 MFD capacitor may be old. If your unit is more than 5 years old, try replacing this capacitor. Also, if your cable run is over 200 feet, make sure that you are using the proper wire size. See Table 2. For cable runs over 300 feet, you may wish to move the motor capacitor to the tower. This allows you to run only 6 wires from the control to the rotator, so that you can reduce wire

resistance by doubling up wires or using fewer, heavier wires.

If the electrical circuit is working, then check for mechanical problems. Look for mast binding or thrust bearing misalignment if you have experienced strong winds recently. If the temperature is less than -30 deg. F (-34 deg. C), the rotator will be very sluggish or may not run at all! This is normal. Do not try to rotate with the DCU-2 control if temperatures are below -30 deg. F! Older models of HAM-M, 11, 111, IV and T2X rotators may be very sluggish at temperatures less than 0 degrees F.

Problem	Possible Cause
Antenna Bearing doesn't match display	Mast slipped in rotator clamp
	Antenna slipped on mast
	DCU-2 Calibration not performed
Current Bearing changes randomly or does not change at all	Potentiometer broken or burned-up
	Shorts or opens in control cable
	Extremely high RF field near rotator
	DCU-2 MPU or A/D failure
	Tower or DCU-2 not grounded
Antenna Bearing changes by itself	Brake wedge failure
	DCU-2 MPU failure
Current Bearing changes +/- less than 3 degrees	Antenna rocking in high winds
	Potentiometer dirty or poor connection
	High RF field near rotator
	Long (200') control cable
Rotator unable to reach target bearing	Temperature less than -30 degrees F
	Broken teeth in gears
	Shorts or opens in control cable
	Thermal cut-out in power transformer
	Mast binding in tower
	Old motor-start capacitor
	High winds, high wind area
	Control cable wire size too small
	DCU-2 MPU failure
Rotator slow to reach target bearing	Temperature between -30 and 0 degrees F
	Broken teeth in gears
	Mast binding in tower
	Old motor-start capacitor
	High winds, high wind area

Table 4 Trouble Shooting Suggestions

Checking the Control Unit Voltages

To check the control unit voltages, first remove the rotator control cable from the DCU-2 control box, then plug the line cord into a 120 VAC outlet. Set the target bearing

at least 10 degrees from the current bearing. Press "ROTATE" to check the voltages on pins 2, 5, and 6. Check for the following voltages on the 8 pin connector:

Pin #'s	Ambient State	Press "ROTATE" (see note)
1-2	0	30 VAC
1-5	0	30 VA C (for CW rotation to target)
1-6	0	30 VA C (for CCW rotation to target)
4-8	0	0
3-1	+ 8.0 VDC	+ 8.0 VDC
3-1	0 to 4.0VDC	<i>With Rotator Cable Connected</i>

Table 5 Voltage Readings

NOTE:

You have 8 seconds after pressing "ROTATE" to make each measurement. The DCU-2 checks for movement, and after 8 seconds without movement, it stops trying to

rotate. You may wish to make your meter connections with alligator clips, then press "ROTATE" when you are ready to read the meter.

Checking the Rotator Resistances

You may possibly avoid bringing the rotator down from the tower by making electrical resistance checks on the control cable.

Disconnect the control cable from the control box. Check for the following resistances.

Description	Pin #'s	Approximate Resistance (ohms)
Brake Solenoid	1-2	0.75 + cable resistance
1/2 Motor Winding	1-8	2.5 +cable resistance
1/2 Motor Winding	1-4	2.5 +cable resistance
1/2 Motor Winding + switch	1-6	2.5 +cable resistance
Entire Motor	4-8	4.5 + cable resistance
Right Limit Switch	5-8	0 +cable resistance
Left Limit Switch	4-6	0 + cable resistance
Entire Pot	3-7	500 + cable resistance
Pot Arm to + End	1-3	0 to 500 (0 at full CCW)
Pot Arm to - End	1-7	0 to 500 (500 at full CCW)

Table 6 Rotator Resistance Readings

Heading Notes

Reading and control near the stops may not always go to the exact location instructed. Near the right stop the voltage is very low and noise and AC hum interfere with the readings. This is due to the way the rotators are wired with the position pot center wiper

at ground. Headings between 180 and 200 degrees may be difficult to reach with automatic control. A similar issue is found between 180 right stop and 160 degrees when rotating off of the right stop.

DCU-2 Digital Antenna Rotator Controller

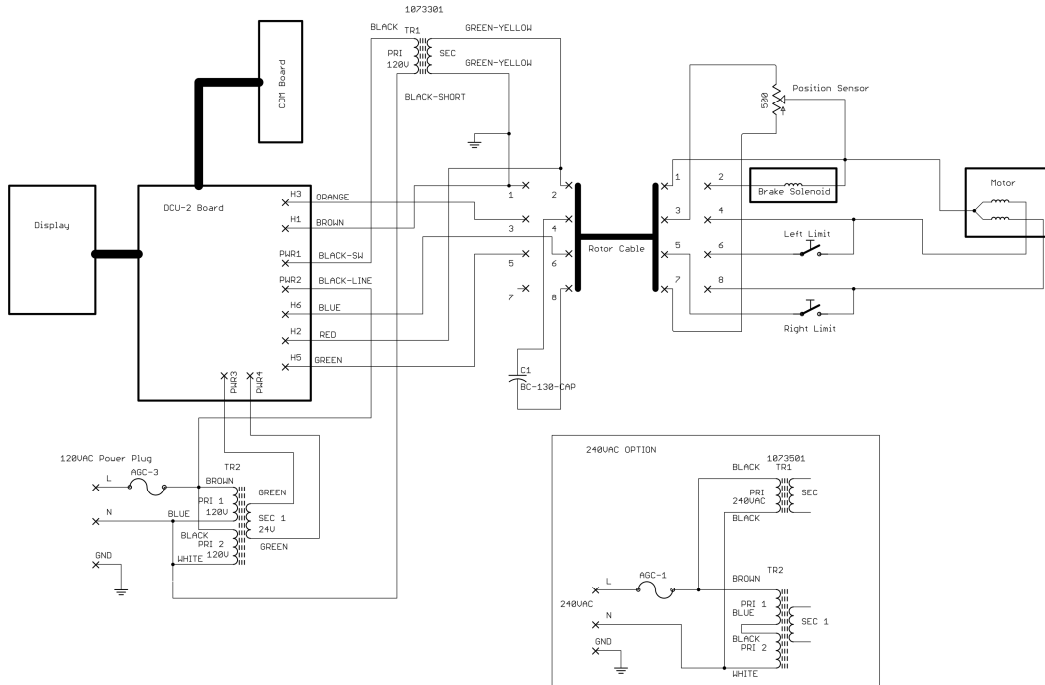

Figure 7 DCU-2 Block Diagram

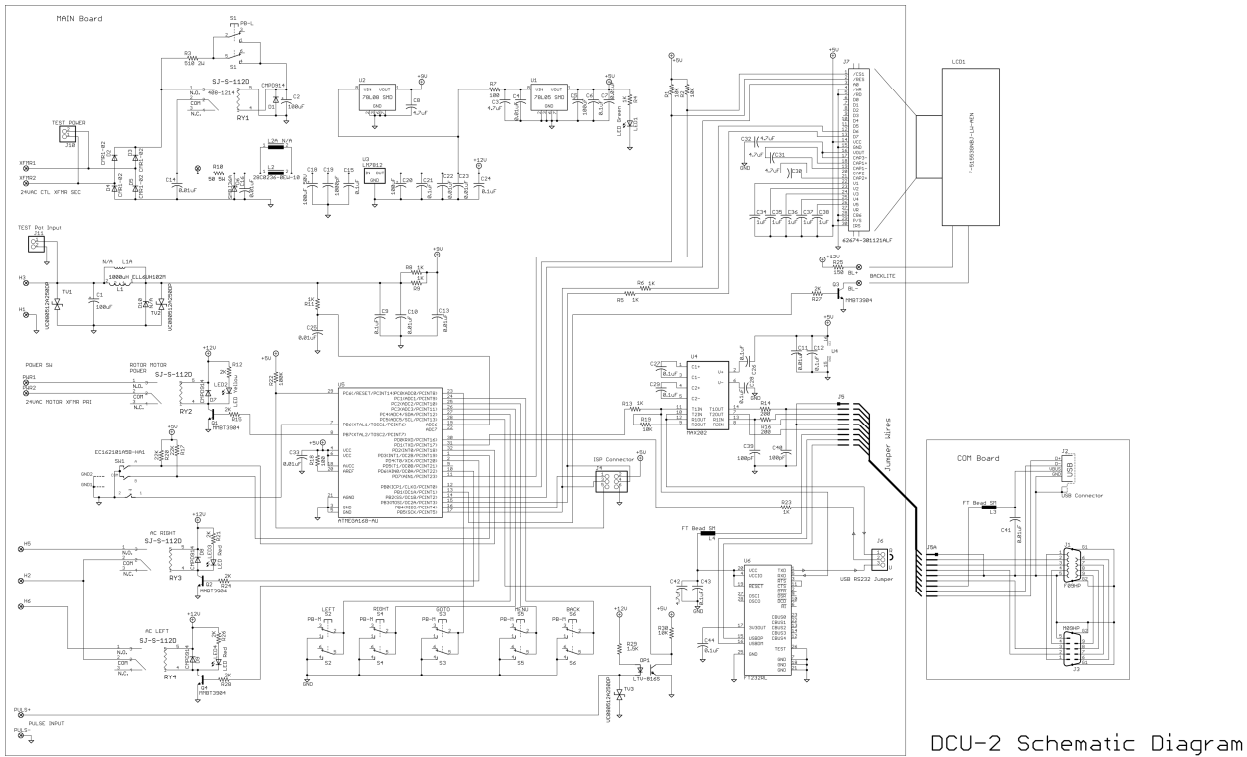

Figure 8 DCU-2 Main PCB Schematic

DCU-2 Schematic Diagram

Table 7 Chassis Parts

Part Num	Value	Quantity
500160	10-24X5/8 SS Screw	1
520057	6-32X3/8 Black type F	8
551153	10-24 wing nut SS	1
554071	10-24 SS NUT	1
556990	8-32 SS NUT	4
640076	8 pin Female Jones Connector	1
667621	#10 ring lug crimp on	3
671673	Spade lug crimp on	2
1073301	MAIN transformer 120V (for 120VAC units only)	1
1073501	MAIN transformer 240V (optional for 240VAC units only)	1
5017702	Meter Transformer	1
5104700	#8 EXT TOOTH Lock Washer	4
270-6220-1	220uF 25V capacitor	1
610-5020	Power Connector	1
654-0187	4-40X3/16 screw	8
654-0250	4-40X1/4 screw	4
654-0500-CP	4-40X1/2 SS Flat Head Screw	2
654-0500S	4-40X1/2 SS screw	4
656-0250S	6-32X1/4 SS screws	7
705-0440S-K	4-40 KEP NUT	9
705-0632S-K	6-32 KEP Nut	7
711-1037-EX	#10 EXT TOOTH Lock Washer	2
716B-0250	4-40 X 1/4 hex threaded spacers	4
716B-0250	4-40X1/4 hex threaded spacers	4
716B-0500	4-40 X 1/2 hex threaded spacers	4
740200L	130 uF Motor Run Capacitor	1
745-2149	white tie wraps	2
745-2158B	black tie wraps	2
755-2148	Fuse Holder	1
760-0033	Knob	1
770-6014	Grommet	2
782-DCU2	Front Panel Decal	1
800-DCU2	Chassis	1
802-DCU2	Front Panel	1
803-DCU2	Back Panel	1
5086100	Power Cord (120VAC)	1
5079800	Power Cord (optional 240VAC)	1
755-0103	3A 250V Fast Blow AGC-3 (120VAC)	1
755-0101	1A 250V Fast Blow AGC-1 (optional 240VAC)	1
810-8800	Top Cover	1
810-8801	Bottom Cover	1

Table 8 Printed Circuit Board Parts

Part Num	Value	Parts	Qty
270S-6100	100uF	C1, C2, C5, C20	4
270S-6100-2	100uF 50V	C18	1
200S-2100	1000pF	C19	1
200S-4470-1	4.7uF	C3, C8, C30, C31, C32, C42	6
200S-4100	1uF	C34, C35, C36, C37, C38	5
200S-0100	100pF	C39, C40	2
200S-2100	0.01uF	C4, C7, C10, C13, C14, C16, C22, C23, C25, C33, C41	11
200S-3100	0.1uF	C6, C9, C11, C12, C15, C21, C24, C26, C27, C28, C29, C43, C44	13
300S-0914	CMPD914	D1, D7, D8, D9	4
300S-4001	CMR1-02	D2, D3, D4, D5	4
301S-0036	SMBJ36A	D6	1
612S-5030	62674-301121ALF	J7	1
401S-6100-2	1000uH ELL6UH102M	L1	1
412S-3226	FT Bead SM	L3, L4	2
356-0816-SM	LTV-816S	OP1	1
305-3904-SM	MMBT3904	Q1, Q2, Q3, Q4	4
100S-4100	10K	R1, R2, R19, R30	4
100S-3200	2K	R12, R15, R21, R24, R26, R27, R28	7
100S-2200	200	R14, R16	2
100S-4100	22K	R17, R20	2
100S-5100	100K	R22	1
100S-2150	150	R25	1
100S-3150	1.5K	R29	1
100S-3100	1K	R4, R5, R6, R8, R9, R11, R13, R23	8
100S-2100	100	R7, R18	2
304S-12250	VC080512A250DP	TV1, TV2, TV3	3
307S-78L05	78L05 SMD	U1	1
307S-78L08	78L08 SMD	U2	1
325-0202-SM	MAX202	U4	1
328-0168-SM	ATMEGA168-AU	U5	1
325-0232RL-SM	FT232RL	U6	1
105-1510W	50 5W	R10	1
104-2560	560 2W	R3	1
408-1214	SJ-S-112D	RY1, RY2, RY3, RY4	4
610-3009	F09HP	J1	1
601-8201	USB Connector	J2	1
610-3109	M09HP	J3	1
412-6131-PW	28C0236-0EW-10	L2	1
354-51320	F-51553GNBJ-LW- AEN	LCD1	1
351-5002	LED Green	LED1	1

DCU-2 Digital Antenna Rotator Controller

351-5005	LED Yellow	LED2	1
351-5004	LED Red	LED3, LED4	2
504-2022	PB-L	S1	1
504-4022M	PB-M	S2, S3, S4, S5, S6	5
580-0028	EC162101A5B-HA1	SW1	1
307-7812	LM7812	U3	1
750-0232	TO220 Heatsink		1
760-2059	White Push Button Cap		5
760-2052	Red Push Button Cap		1
654-0250	4-40X1/4 screw		1
705-0440	4-40 nut		1
612-4001	Shorting Jumper		1
862-DCU2	PC BOARD		1
718-1425-0250	0.250 nylon spacer		4
718-1425-0125	0.125 nylon spacer		4

How to Get Factory Service

If service is required, the unit must be packed and sent prepaid to:

hy-gain.

**308 Industrial Park Rd.
Starkville, MS 39759 USA**

Ph: (662) 323-9538 FAX: (662) 323-6551

For units that are in warranty, no charges will be made for any repair work required. For out-of-warranty units, call the Warranty Service Department for prices. The price includes rebuilding the unit, replacing all defective and/or worn parts, and return freight charges. Hy-Gain reserves

the right to change prices at its option. When returning items for repair, a check or money order for the repair charges must be included. Be sure to include your name, address, zip code, and telephone number. Also, give a brief description of the problem.