

AMERITRON RCS-8V

Remote Coax
Switch

INSTRUCTION MANUAL

PLEASE READ THIS MANUAL BEFORE OPERATING THIS EQUIPMENT !

AMERITRON

116 Willow Road
Starkville, MS 39759 USA
662-323-8211

INTRODUCTION

The Ameritron RCS-8V is a remote controlled coaxial RF switch that will operate with negligible loss, radiation and VSWR at all frequencies up to 250 MHz. Only a slight compromise in VSWR occurs at 450 MHz. Power rating is four kilowatts PEP below 30 MHz and one kilowatt PEP at 150 MHz.

The RCS-8V permits the operation of up to five separated antennas with only one coax feedline. A rotor or telephone type control cable with a minimum of five conductors is required.

The control console selects the supply voltage for the relay box. The front panel has five LED's that indicate the antenna that is in use.

The RCS-8V operates on +12 Vdc voltage. The RCS-8V is supplied with a +12 Vdc adaptor for 100-120 Vac input 50/60 Hz. The RCS-8VX is supplied with a +12 Vdc adaptor for 200 to 240 Vac input 50/60 Hz.

The RCS-8VL models include Gas Discharge Tubes attached to each antenna terminal.

INSTALLATION

The relay box may be mounted on a tower leg, mast or building wall. The mounting hardware furnished will accept a tubular mast up to 1 1/2" diameter.

If the box is mounted on a building wall discard the "U" bolt assembly and use two 1/2" screws to attach the bracket to the wall.

The relay box must be mounted with the connectors down. Do not attempt to air seal the relay box. Install drip loops below the box if the feedlines are brought in from a higher location. Lightning retarding loops are recommended precaution on all cables (see Figure 1).

Relay Box Cable Connections

Inexpensive five or more conductor rotor or telephone cable can be used to connect the relay box to the control console. The only requirement is that the cable be physically able to survive the environment it is installed. Wire gauge and voltage breakdown are not critical. Conductor and ground return (through the coax shield) resistances can total 80 ohms before operation becomes compromised.

Remove the four screws at the corners of the panel and remove the cover. Route one end of the control cable through the bushing in the panel and through the plastic cable clamp.

Connect five of the wires in the cable to terminals 1 to 5. Make a note of the color that is connected to each terminal. If a sixth wire is available in the control cable, connect it to the "G" terminal.

Reinstall the cover on the panel using the self-tapping screws previously removed.

The indoor console and outdoor relay box must have a ground reference to each other. Either by RF, earth ground, or a ground wire in the control cable.

LIGHTNING RETARDING LOOPS

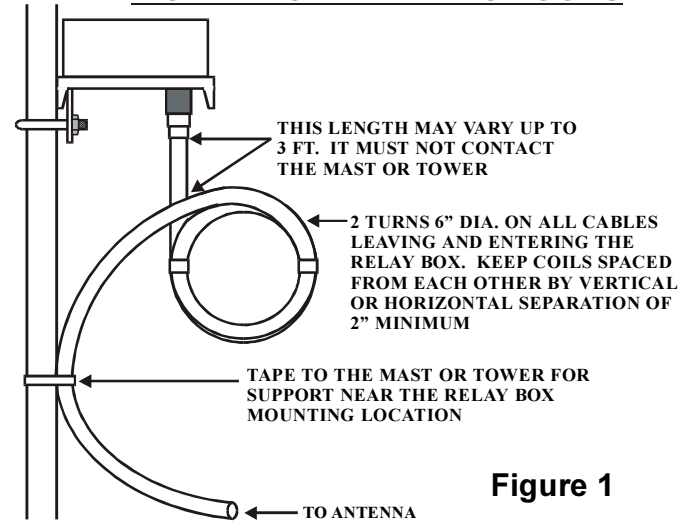

Figure 1

Relay Box Antenna Connections

Connect your antennas to coax connectors numbered 1-5 and note which antenna is connected to each connector.

Connect the feedline to the connector marked "INPUT".

If control power is removed, the relay box automatically disconnects the "input" feed connection from all antenna ports.

Unselected antenna ports may be automatically grounded or isolated. The RCS-8V is shipped with the ports isolated. To automatically ground the unselected port, a short jumper must be installed as shown in Figure 2.

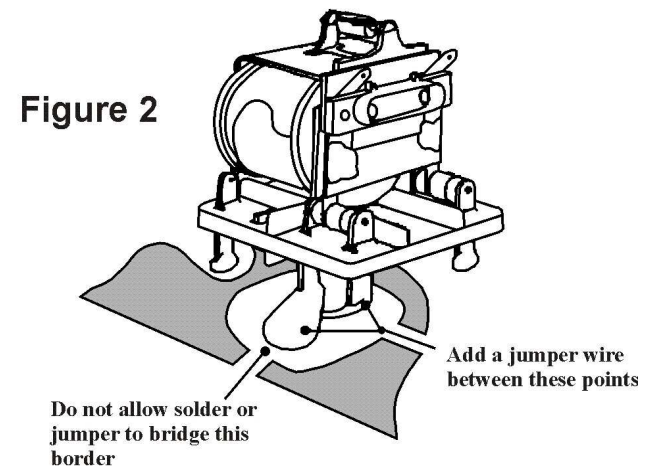

More than one antenna port can be "picked up" at one time by applying control voltage to more than one relay at

one time. This allows the user considerable flexibility in stacking arrays of similar antennas.

The “input” port is the common connection port. It can also be used as an output, selecting up to five inputs, or left floating if cross-matrix switching between the various “Ant” ports is desired.

Control Console Connections

Locate the RCS-8V control console at a convenient location on the station operating desk.

The control console supplies 12V DC control voltages. Caution must be exercised when connecting the RCS-8V to prevent damage to station equipment.

Connect the five wires in the cable to terminals 1-5. Use the same color code that was used on the relay box. If a sixth wire is available in the control cable, connect it to the “G” terminal.

IMPORTANT: Connect the “G” terminal to the station ground buss.

OPERATION

1. Plug the adaptor into a proper outlet.
2. Connect the adaptor’s plug into the power jack of the console.
3. Place the PWR switch in the “ON” position.
4. Rotate the SELECT control and observe the lights one through five.

The switch positions are numbered on the front of the control box and a space is provided above each position so you can pencil in a designation for each antenna.

IMPORTANT

1. NEVER switch antennas with RF power applied to the master feedline. Damage to the switching contacts may result from “hot switching”.
2. If one of the lights is dimmer than the rest, it is an indication of a short in the control cable or between terminal screws.

PARTS LIST

Designation	Description	Ameritron Part #
C1	0.1 uF, 50 V	200-3100
C2	0.1 uF, 50 V	200-3100
LED 1-5	Red LED	351-5002
R1	470 ohm, ½ W	101-2470
RELAYS	SPDT Relay	406-4681-1
S1	Rotary Switch	500-0563
S2	On-Off toggle switch	503-1233
GDT1-5	Lightning Suppressor (L Model Only)	304-6120
	12VDC Adapter 100-120 VAC Mains	MFJ-1312D
	12VDC Adapter 200-240 VAC Mains	MFJ-1312DX

SCHEMATIC

"L" Model

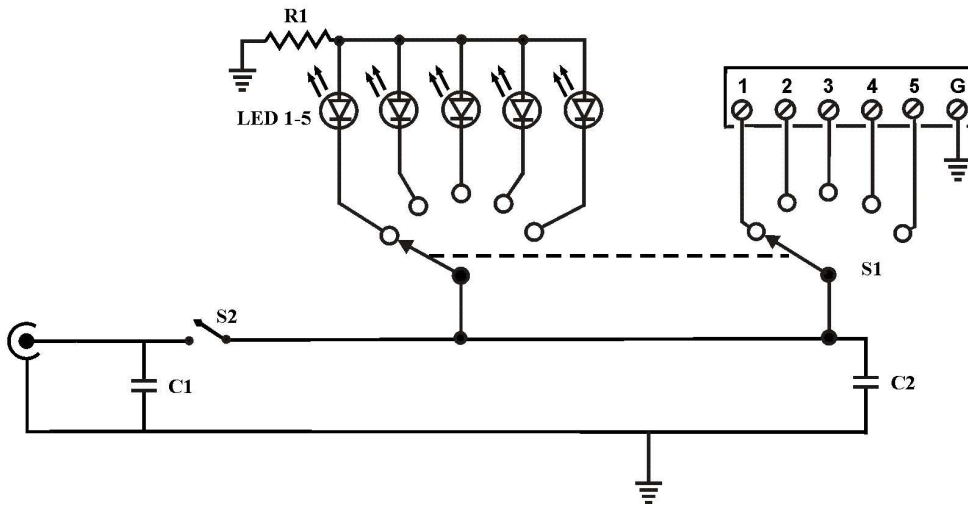
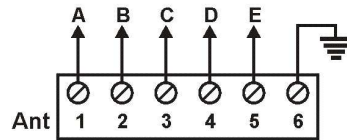
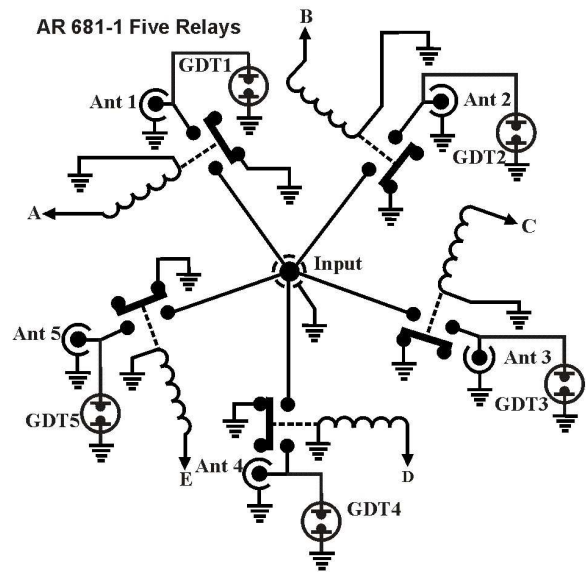
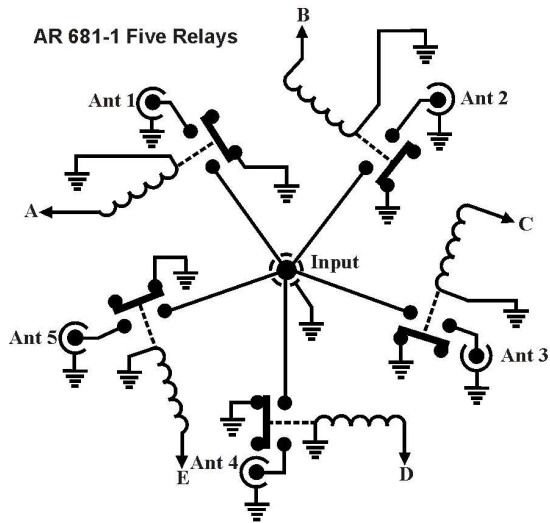

Notes:

Notes:

DISCLAIMER

Information in this manual is designed for **user purposes only** and is *not* intended to supersede information contained in customer regulations, technical manuals/documents, positional handbooks, or other official publications. The copy of this manual provided to the customer will *not* be updated to reflect current data.

Customers using this manual should report errors or omissions, recommendations for improvements, or other comments to Ameritron 116 Willow Road, Starkville, MS 39759. Phone: (662) 323-8211; FAX: (662) 323-6551. Business hours: M-F 8-4:30 CST.

AMERITRON

**116 Willow Road
Starkville, MS 39759 USA
662-323-8211**

LIMITED WARRANTY

Ameritron warrants to the original purchaser that this product shall be free from defects in material or workmanship for one year from the date of original purchase. During the warranty period, Ameritron (or an authorized Ameritron service facility) will provide free of charge both parts and labor necessary to correct defects in material or workmanship.

To obtain such warranty service, the original purchaser must:

1. Complete and send in the Warranty Registration Card.
2. Notify Ameritron or its nearest authorized service facility, as soon as possible after discovery of a possible defect, of:
 - a. The model number and serial number, if any;
 - b. The identity of the seller and the approximate date of purchase;
 - c. A detailed description of the problem, including details on the equipment.
3. Deliver the product to the Ameritron or the nearest authorized service facility, or ship the same in its original container or equivalent, fully insured and with shipping charges prepaid.

Correct maintenance, repair, and use are important to obtain proper performance from this product. Therefore, carefully read the Instruction Manual. This warranty does not apply to any defect that Ameritron determines is due to:

1. Improper maintenance or repair, including the installation of parts or accessories that do not conform to the quality and specifications of the original parts.
2. Misuse, abuse, neglect or improper installation.
3. Accidental or intentional damage.

All implied warranties, if any, terminate one (1) year from the date of the original purchase.

The foregoing constitutes Ameritron's entire obligation with respect to this product, and the original purchaser and any user or owner shall have no remedy and no claim for incidental or consequential damages. Some states do not allow limitations on how long an implied warranty lasts or do not allow the exclusion or limitation of incidental or consequential damage, so the above limitation and exclusion may not apply to you.

This warranty gives specific legal rights and you may also have other rights, which vary from state to state.