

RHM12

OPERATION INSTRUCTIONS

To use the antenna properly, read these instructions thoroughly before using it. Keep this manual carefully at hand for later use.

Safety Precautions

Note beforehand that the company shall not be liable for any damages suffered by the customers or third parties in using that product, or for any failures and faults that occur the use or misuse of this product, unless otherwise provided for under the law.

■ Type and meaning of the marks

DANGER	This mark indicates an imminently hazardous situation, which, if not avoided, could result in death or serious injury.
WARNING	This mark indicates a potentially hazardous situation, which, if not avoided, could result in death or serious injury.
CAUTION	This mark indicates a potentially hazardous situation, which, if not avoided, may result in minor or moderate injury or only property damage.

DANGER

- Don't install the antenna on a rainy or windy day since it is dangerous.
- Don't touch the antenna during transmitting since it is dangerous.
- If there is a thunderstorm during operation, stop the operation immediately and remove the cable from the transceiver. If that doesn't make it in time, don't touch the antenna and the cable. It may be severely injured or die due to getting and electronic shock from a lightning strike.

WARNING

- Don't drop the antenna, tools and attachment when installing the antenna in the height. Install the antenna after assembling it on the ground.
- Install the antenna firmly not to fall down due to the strong wind. Even if falling down the antenna, locate the antenna at the safe place where people and building are not inflicted injures.
- Don't attempt to install the antenna only by yourself. Installing the antenna alone on the roof may lead you dangerous accident. Always ask your friends for help installing the antenna.

CAUTION

- Make sure to adjust the antenna before using it.
- Install the antenna as far away as possible from any obstacles to obtain its maximum performance.
- Keeping transmitting with high VSWR may cause the transceiver to be damaged. Stop transmitting immediately and check the antenna.
- When transmitting, operate within the specification of the transmission power. It is a big burden on the antenna on FT8 etc. Don't operate over the specification of the transmission power. The antenna may be damaged.

● **Description**

1. The RHM12 can be operated on 1.9/3.5MHz bands using the optional coils (not included). It is also possible to tune the emergency communication frequency (4650kHz) using the 3.5MHz optional coil. (Japan only)
2. It is easy to adjust the frequency by the adjustment position scale.
3. Approx. 2 m rod element makes high efficiency and band expansion.
4. It is easy to lock the coils.
5. It is suitable for portable operation.

* This product is not waterproofing so it cannot be used at the rainy day and at the place where it gets wet.
 * This product is designed as portable use and temporary installation. Don't use it while driving.

● **Parts List**

Please confirm if all parts of the below list are contained in the package.

Coil body	1
Rod element	1
440MHz element	1
440MHz radial	1
Element adjusting string	1

● **Assembly drawing**

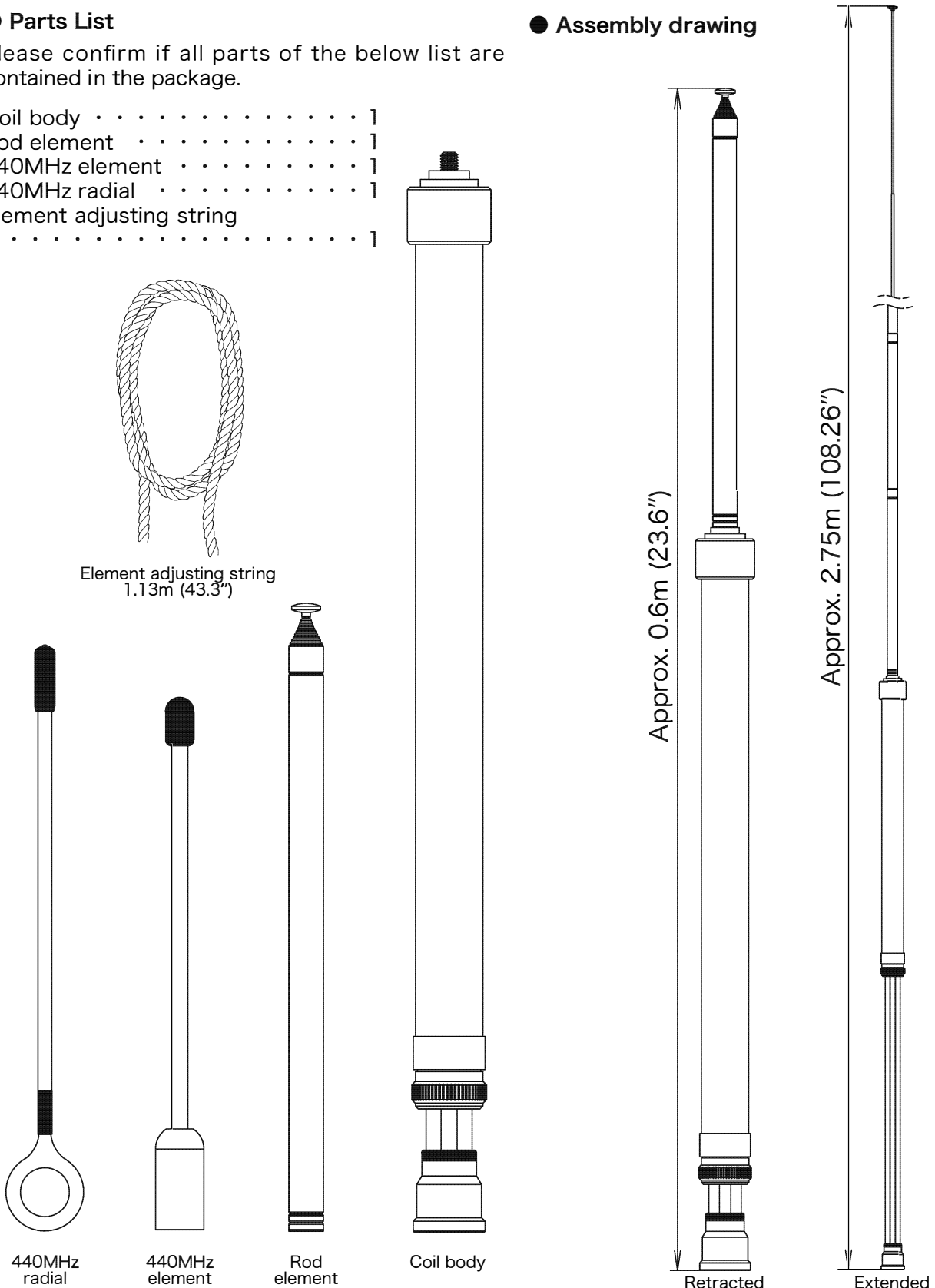

● How to ground (counter poise)

This product needs ground for all bands (except for 440MHz). SWR will not be lower without ground. SWR meter shows lower SWR value in spite of lack of ground because high frequency current superimposes on the coaxial cable. Radio wave radiates from the coaxial cable. It may cause interference. Make sure to ground. Our CMF2000 (common mode filter) has deterrent effect.

Refer to the below examples to ground.

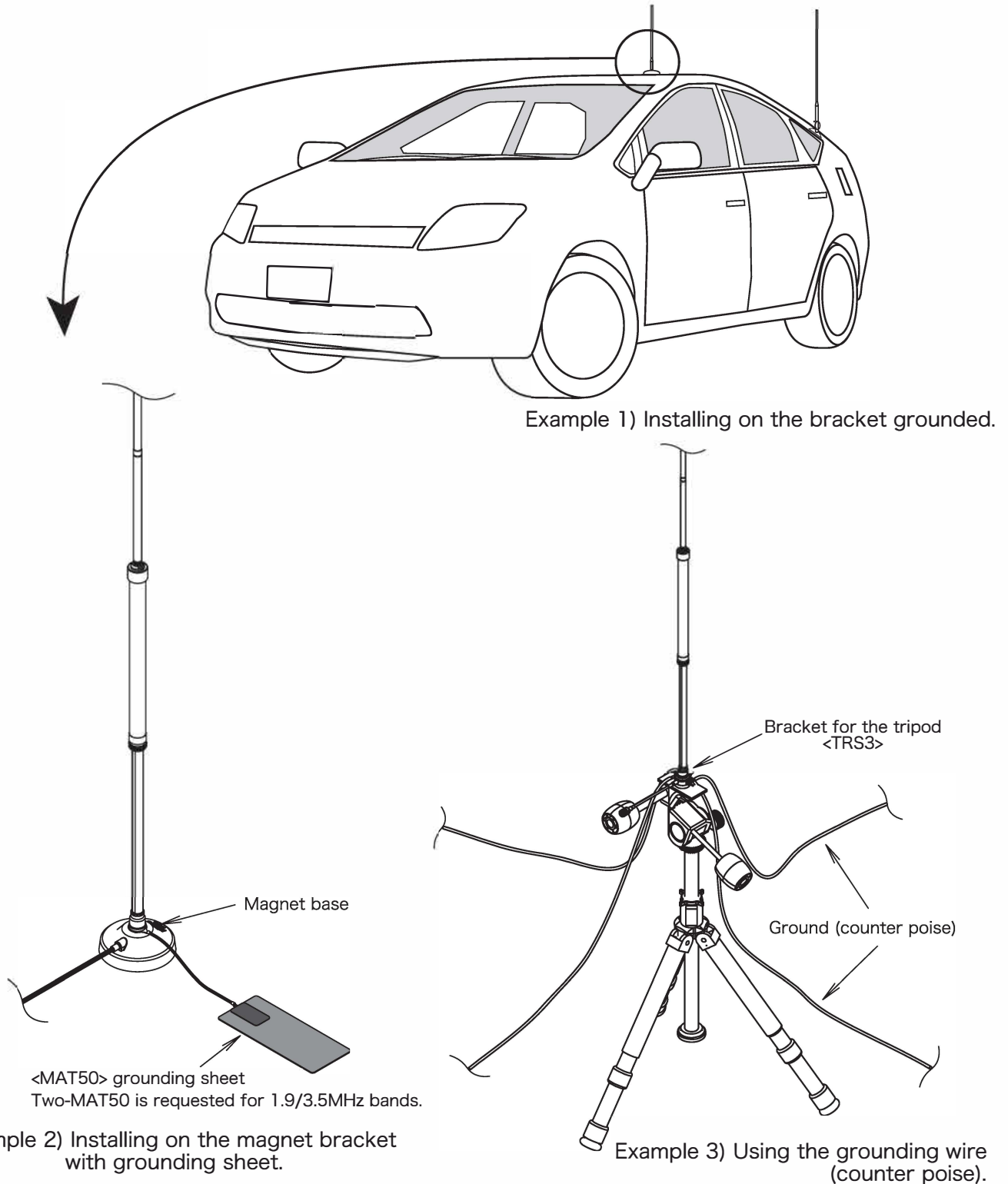

【Note】

- The number and length of grounding wire are determined depending on the installation place, conditions, and frequency.
- It is susceptible to wind because the antenna is long. In case of installing it on the tripod, use the counterweight etc. to prevent falling down.
- This product is designed as portable use and temporary installation. Don't use it while driving.

● Adjustment

Move the coil up and down referring to the adjustment position scale to adjust the frequency.

< Adjusting on 1.9/3.5MHz >

1.9MHz band and 3.5MHz band can be operated using RHMC12 (optional coil set). 4630kHz can be tuned using 3.5MHz optional coil.



1.9MHz band coil



3.5MHz band coil

1. Connect (A)(coil body) → (B)(optional coil) → (C)(rod element) from the bottom. Extend the rod element to the maximum.
2. Loosen the lock nut on the coil body and slide the coil to find the resonance point (best SWR).

【Advice on one point】

Make the transceiver receive mode and turn up the volume at AM mode. Slide the coil body and tune the maximum noise. It will be helpful to find the resonance point (best SWR).

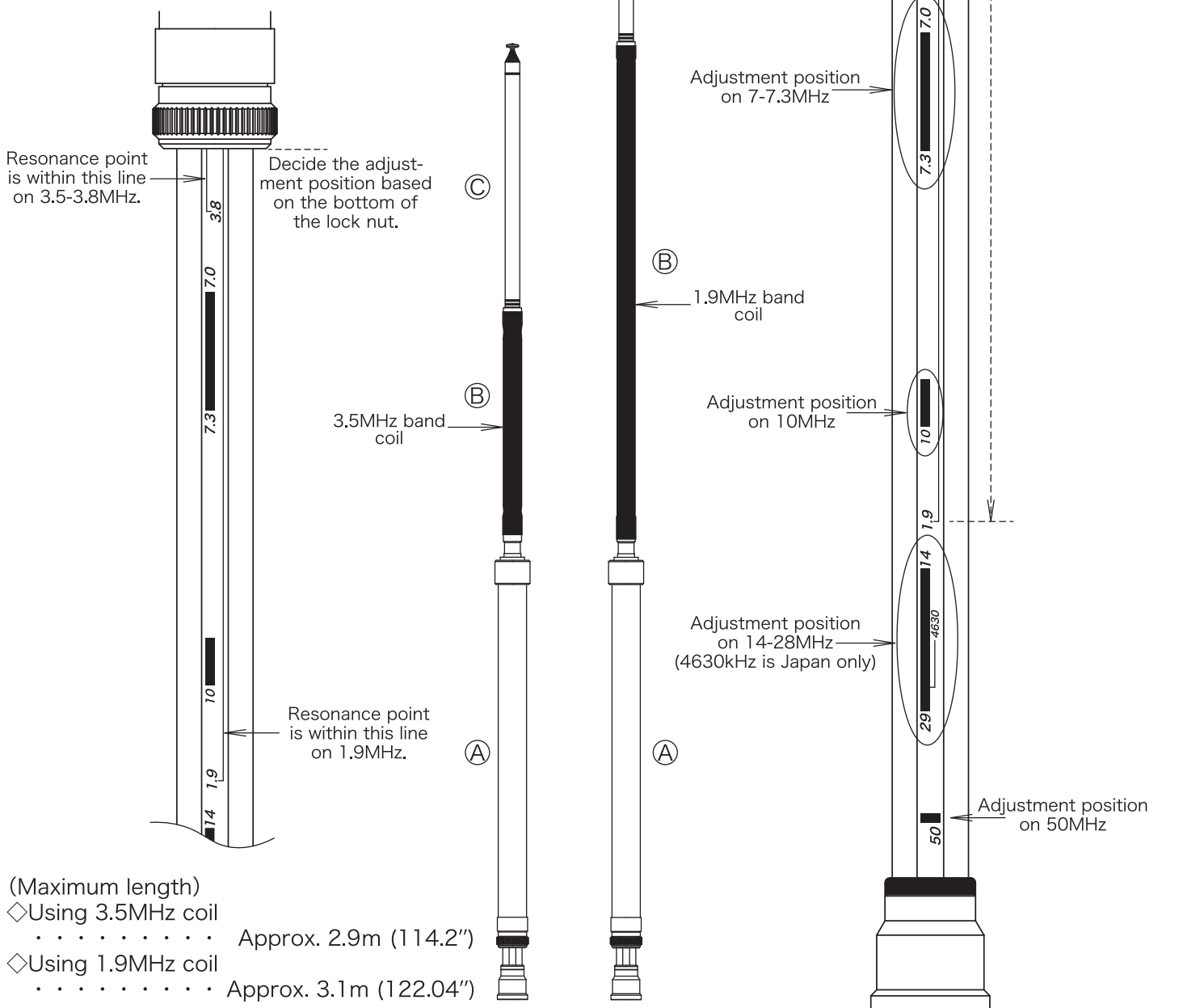

<Adjusting on 7 - 28MHz>

The rod element only is used on 7 - 28MHz.

Keep expanding the rod element to the maximum. (It is not necessary to adjust the length) Slid the coil body only to adjust the frequencies.

1. Connect (A)(coil body) → (B)(rod element) and extend the rod element to the maximum.
2. Loosen the lock nut on the coil body and slide the coil to find the resonance point (best SWR).

【Advice on one point】

Make the transceiver receive mode and turn up the volume at AM mode. Slide the coil and tune the maximum noise. It will be helpful to find the resonance point (best SWR). Slide the coil slowly at the higher bands because the resonance point will be moved substantially by a little move.

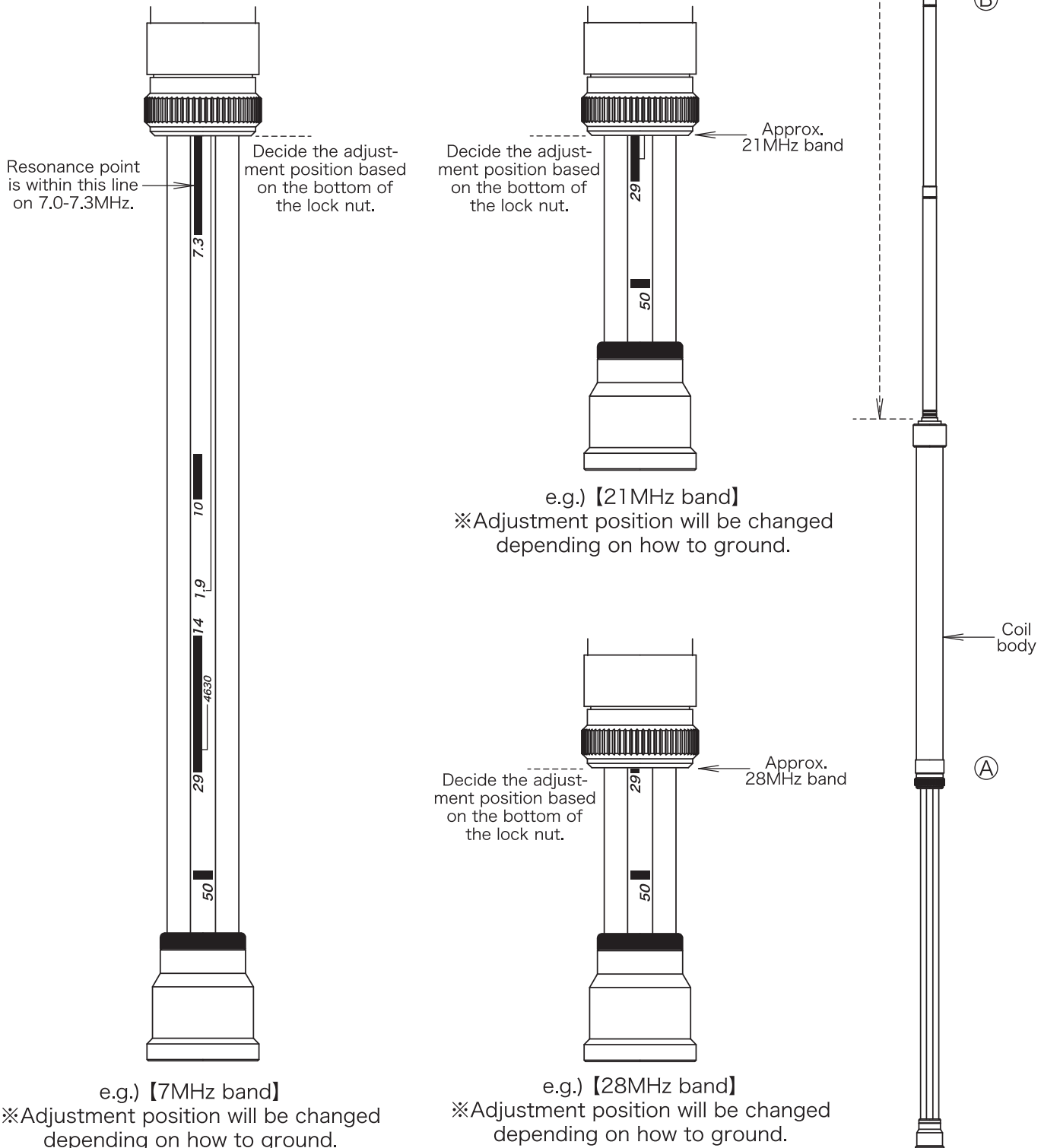

<Adjusting on 50/144MHz band>

Keep the coil body down at the very bottom on 50/144MHz band. Make the rod element length approx. 1.13m (counting 6 rod from the bottom + a few cm). Adjust the rod element length as same as element adjusting string (included).

At this status the resonance point (best SWR) on 50MHz band is approx. 50.0MHz and the resonance point (best SWR) on 144MHz band is approx. 145.0MHz. It will be shifted depending on the installation conditions and grounded. Do the fine tuning by SWR meter or analyzer. (The frequency becomes lower if expanding the rod element and the frequency becomes higher if retracting the rod element.)

※Our data is based on the measurement on the trunk grid bracket grounded.

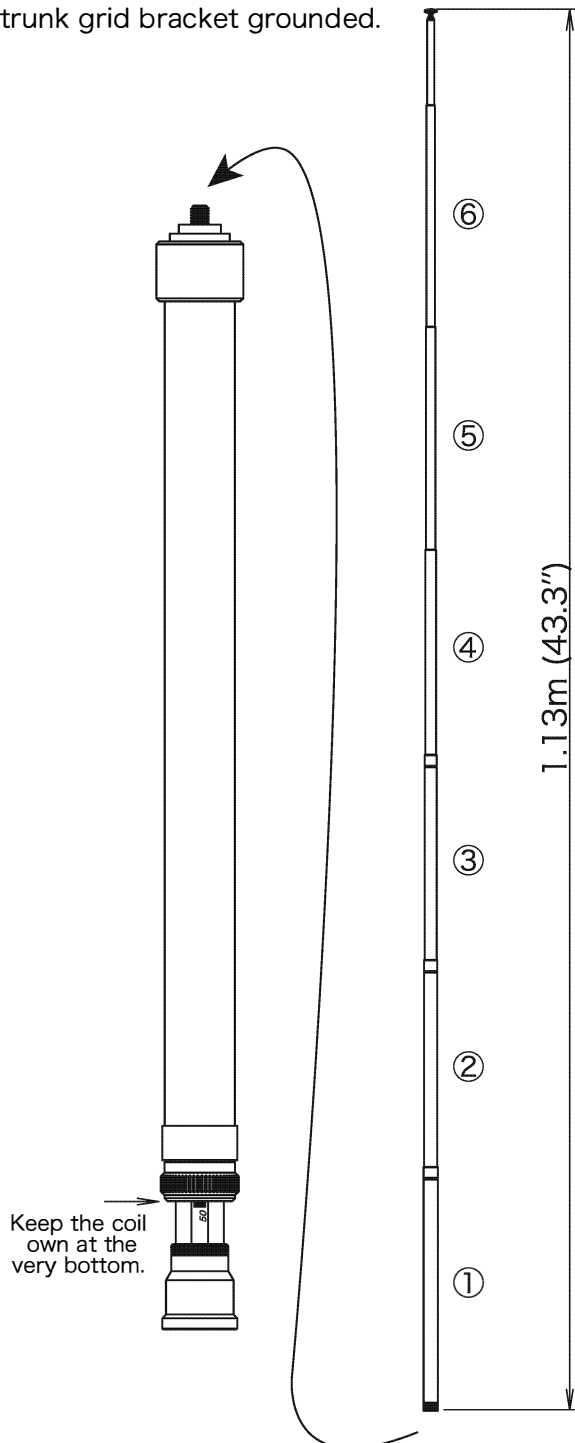

Adjust the rod element length using with the element adjusting string.

<Regarding 430MHz band>

It is possible to operate on 440MHz band using 430MHz radial and 440MHz element. (SWR may not be lower depending on the installation conditions and grounded.)

※Our data is based on the measurement on the trunk grid brackets grounded.

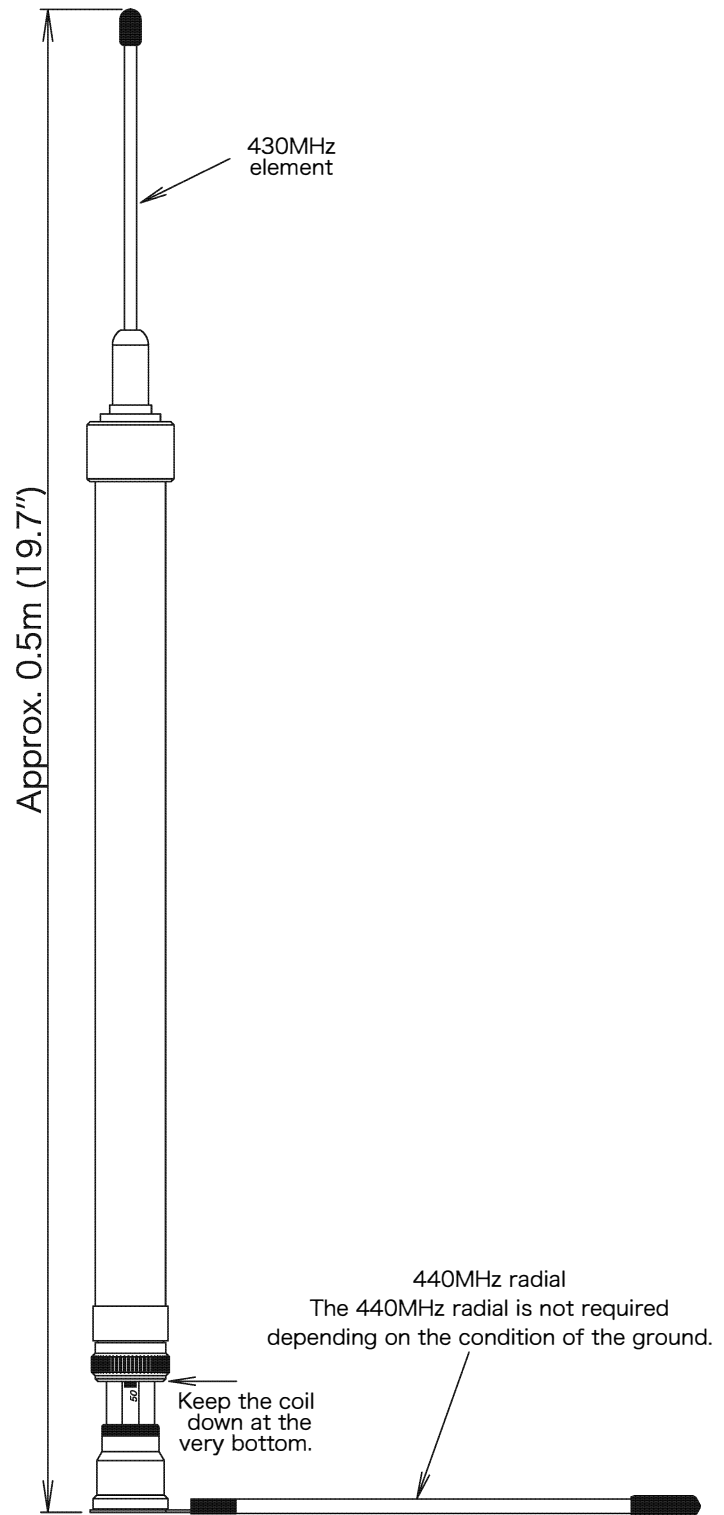

● Prevention of interference due to lack of ground

The high frequency current at some frequency band may superimpose on the coaxial cable due to lack of ground. If the high frequency current superimposes on the coaxial cable, the device may be inoperable on the transmission status. We recommend to use our CMF2000 to prevent the defects. It is possible to cut the high frequency current to the coaxial cable.

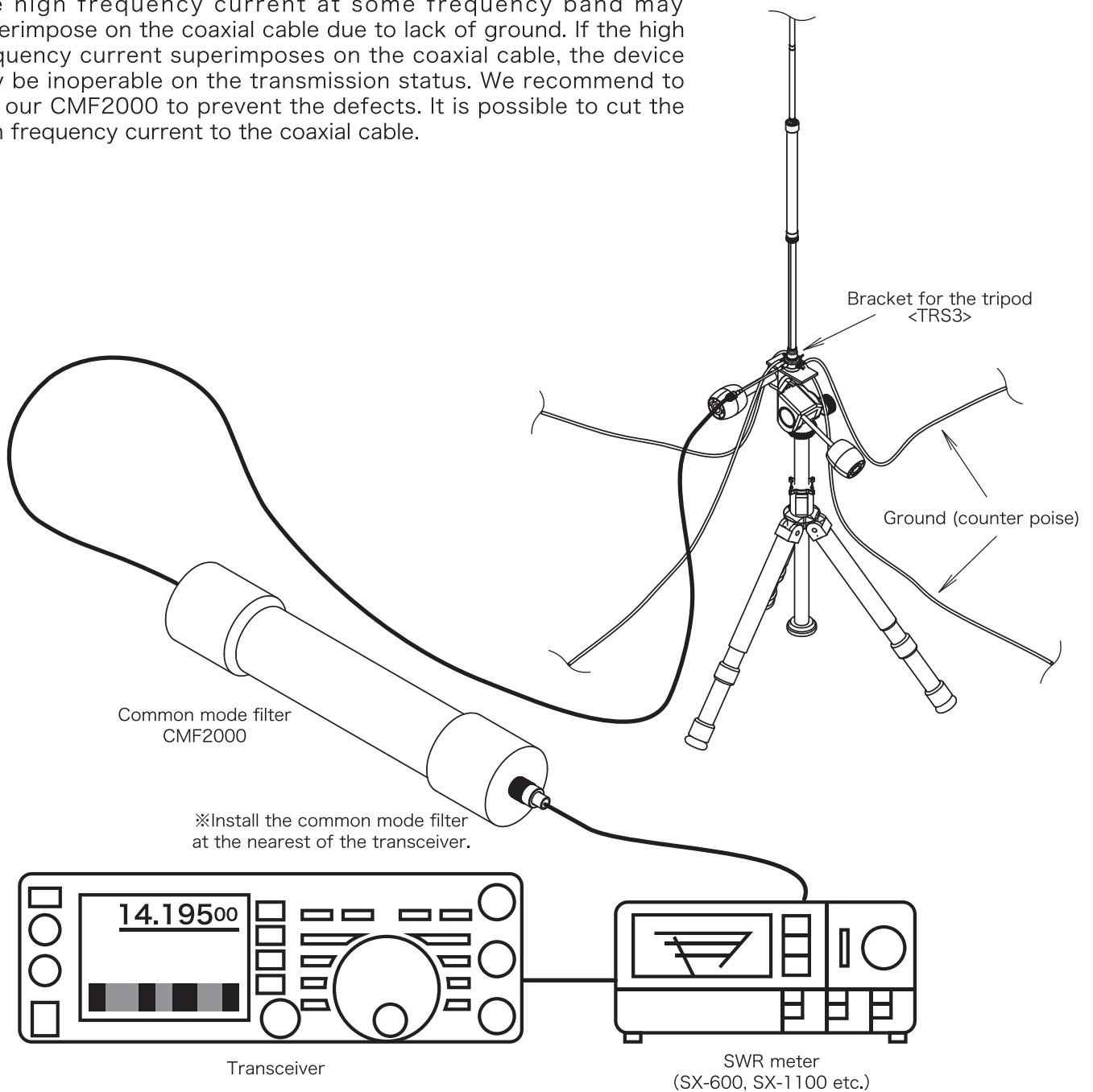

● Precautions for use

- This product is designed as portable use or temporary installation. It cannot be used as fixed station antenna or permanent installation. It is not used at the rainy day because it is not waterproofing.
- Do not use it at strong wind day. It may be fell down or damaged.
- It is possible to install it on vehicle when stopped only. It cannot be used while driving. Uninstall the antenna while driving. If driving a car with the antenna, the antenna may be broken or damaged. Make sure to uninstall the antenna while driving.
- It is susceptible to wind because the antenna is very long. In case of installing on the tripod, use the counterweight etc. to prevent falling down.
- SWR may not be lower depending on ground condition or installation condition. If SWR is not lower, please use the antenna tuner.
- Be careful not to over tighten the lock nut. It may be damaged. Don't use any tools to fasten the lock nut.
- Be careful not to overpower when operating carrier wave such as FM, RTTY, FT8 etc. The device may be broken or damaged. Stop using immediately when you feel something strange.

● Specifications

Frequency	(1.9/3.5MHz)* 7.0 - 440MHz *with optional coil
Impedance	50Ω
Max. power rating	120W (SSB), 40W (FM/CW)
Type	1/4λ (1.9 - 50MHz), 5/8λ (144/440MHz)
Connector	M (UHF connector)
Length	Approx. 0.6 - 2.75m (23.6 - 108.26")
Weight	Approx. 350g (0.77lb)

Point when operating new digital mode FT8 etc.

Operating new digital mode FT8 etc. is a big burden on the antenna and other equipments due to continuous transmission. Operate the **max. power rating at less than 1/5 of SSB(PEP)** on FT8 etc.

- Though these products purchased are manufactured under strict quality control, if damage is caused by transporting, ask your dealer promptly.
- Design and specifications of these products will be changed for future improvement without advance notice.